

# CARY AUDIO

## OWNER'S MANUAL

### **SLP 03**

Balanced Stereo Vacuum Tube  
Preamplifier

NOTE: Before installing your new component, please read this manual carefully as it will inform you of the product specifications, proper installation and correct operating procedures for your unit. Also included in this manual are guidelines on how to service and care for your new Cary Audio Design product.

# TABLE OF CONTENTS

---

<b>Important Safety Instructions</b> .....	2
<b>Welcome</b>	
Thank You .....	5
Product Overview .....	5
Unpacking and Installation.....	6
<b>Specifications</b> .....	7
<b>Operation</b>	
Connections .....	8
Checking Connections .....	8
Switching On .....	8
<b>Controls &amp; Displays</b>	
Front Panel .....	9
Rear Panel .....	10
Remote Control .....	12
<b>Service and Care</b>	
Care and Cleaning .....	13
Factory Service .....	13
Non-Warranty Repairs .....	13
<b>Limited Warranty</b> .....	14

# IMPORTANT SAFETY INSTRUCTIONS

---

**WARNING:** To reduce the risk of fire or electric shock, do not expose this appliance to rain or moisture. The lightning flash with arrowhead symbol within an equilateral triangle is intended to alert the user to the presence of un-insulated dangerous voltage within the product's enclosure that may be of sufficient magnitude to constitute a risk of electric shock to persons.



**CAUTION:** To reduce the risk of electric shock, do not remove the cover. There are no user serviceable parts inside. Please refer to qualified personnel for service.

**ALERT:** The exclamation point within an equilateral triangle is intended to alert the user of the presence of important operating and maintenance (servicing) instructions in the literature accompanying the component.

1. **READ ALL INSTRUCTIONS:** All the safety and operating instructions of your Cary Audio equipment should be read before power is applied to the equipment.
2. **RETAIN OWNER'S MANUAL:** These safety and operating instructions should be retained for future reference.
3. **HEED WARNING:** All warnings on the unit and in the operating instructions should be adhered to.
4. **FOLLOW INSTRUCTIONS:** All operating and use instructions should be followed.
5. **CLEANING:** Unplug the unit from the wall outlet before cleaning. The unit should be cleaned only as recommended by the manufacturer.
6. **ATTACHMENTS: Do not** use attachments not recommended by the unit manufacturer as they may cause hazards.
7. **WATER AND MOISTURE: Do not** use the unit near water - for example, near a bath tub, wash bowl, kitchen sink, or laundry tub; in a wet basement; or near a swimming pool.
8. **ACCESSORIES: Do not** place the unit on an unstable cart, stand, tripod, bracket, or table. The unit may fall, causing serious injury to a child, an adult, or damage to the unit. Mounting of the unit should follow the manufacturer's instructions and should use a mounting accessory recommended by the manufacturer.
9. **VENTILATION:** Slots and openings in the cabinet are provided for ventilation to ensure reliable operation of the unit and to protect it from overheating. These openings must not be blocked or covered. The top or bottom panel openings should never be blocked by placing the unit on a bed, sofa, rug, or other similar surface. The unit should not be installed in a built-in location such as a bookcase or rack unless proper ventilation is provided. There should be free space of at least 6 inches (16cm) above the unit and an opening behind the unit.
10. **GROUNDING OR POLARIZATION:** The unit may be equipped with a polarized alternating current line plug (a plug having one blade wider than the other). This plug will fit into the power outlet only one way. This is a safety feature. If you cannot insert the plug fully into the outlet, try reversing the plug. If the plug should fail to fit, contact a licensed electrician to replace your obsolete outlet. Do not defeat the safety purpose of the polarized plug.
11. **POWER SOURCES:** The unit should be operated only from the type of power source indicated on the marking label. If you are not sure of the type of power supplied to your home, consult your unit dealer or local power company.
12. **POWER CORD PROTECTION:** Power supply cords should be routed so that they are unlikely to be walked on or pinched by items placed on or against them. Pay close attention to cords where they enter a plug, or a convenience receptacle, and the point where they exit from the unit.
13. **OUTDOOR ANTENNA GROUNDING:** If an outside antenna or cable system is connected to the unit, be sure the antenna or cable system is grounded so as to provide protection against voltage surges and built-up static charges. Article 810 of the National Electrical Code, NSI/NFPA 70, provides information regarding proper grounding of the mast and supporting structure, grounding of the lead-in wire to an Antenna-discharge unit, size of grounding conductors, location of antenna-discharge unit, connection to grounding electrodes, and requirements for the grounding electrode.

# IMPORTANT SAFETY INSTRUCTIONS

---

14. **LIGHTNING:** For added protection for the unit during a lightning storm, or when it is left unattended and unused for long periods of time, unplug it from the wall outlet and disconnect the antenna or cable system. This will prevent damage to the unit due to lightning and power line surges.
15. **POWER LINES:** An outside antenna system should not be located in the vicinity of overhead power lines or other electric light or power circuits, or where it can fall into such power lines or circuits. When installing an outside antenna system, take extreme care to keep from touching such power lines or circuits as contact with them might be fatal.
16. **OVERLOADING:** Do not overload wall outlets, extension cords, or integral convenience receptacles as this can result in a risk of fire or electric shock.
17. **OBJECT AND LIQUID ENTRY:** Never push objects of any kind into the unit through openings as they may touch dangerous voltage points or short-out parts that could result in a fire or electric shock. Never spill liquid of any kind on the unit.
18. **SERVICING:** Do not attempt to service the unit yourself as opening or removing covers may expose you to dangerous voltage or other hazards. Refer all servicing to qualified service personnel.
19. **REPLACEMENT PARTS:** When replacement parts are required, be sure the service technician has used replacement parts specified by the manufacturer or have the same characteristics as the original part. Unauthorized substitutions may result in fire, electric shock or other hazards.
20. **SAFETY CHECK:** Upon completion of any service or repairs to the unit, ask the service technician to perform safety checks to determine that the unit is in proper operating condition.
21. **WALL OR CEILING MOUNTING:** The unit should be mounted to a wall or ceiling only as recommended by the manufacturer.
22. **HEAT:** The unit should be situated away from heat sources such as radiators, heat registers, stoves, or other units (including amplifiers) that produce heat.
23. **IMPORTANT SAFETY NOTE:** Before connecting a new component to your audio or home theater system it is always good practice to make certain that all components are turned off, and preferably unplugged from their AC power source. Many modern electronics products feature automatic turn-on circuits that may be activated during an installation, causing the potential for damage to electronic components and/or speakers. Such damage is not covered by product warranties and Cary Audio specifically disclaims responsibility for any such damage.

**Power Cord:** The removable power cord that is shipped with the player is specifically designed to be used with this product. Other AC cords may be used, so consult your dealer for advice on AC power cords and high quality wire in your system.



**AC Fuse:** The fuse is located inside the chassis and is not user serviceable. If power does not come on, contact your authorized service representative.

**Wiring:** Cables that run inside of walls should have the appropriate markings to indicate compliance with, and listing by the UL, CSA or other standards required by the UL, CSA, NEC or your local building code. Questions about cables inside of walls should be referred to a qualified custom installer, or a licensed electrician or low-voltage contractor.

**Do Not Open the Cabinet:** There are no user serviceable components inside this product. Opening the cabinet may present a shock hazard, and any modification to the product will void your warranty. If water or any metal object, such as a paper clip, coin, or staple accidentally falls inside the unit, disconnect it from the AC power source immediately and contact Cary Audio for further instructions.

24. **RECORDING COPYRIGHT:** Recording of copyrighted material for other than personal use is illegal without permission of the copyright holder.
25. **NOTE TO CATV SYSTEM INSTALLER:** This reminder is provided to call the CATV system installer's attention to article 820-40 of the NEC, ANSI/NFPA 70, which provides guidelines for proper grounding and, in particular, specifies that the cable ground shall be connected to the grounding system of the building, as close to the point of cable entry as practical.

# IMPORTANT SAFETY INSTRUCTIONS

## 26. FCC INFORMATION FOR USER:

**CAUTION:** ANY changes or modifications not expressly approved by the party responsible for compliance could void the user's authority to operate the equipment.



**NOTE:** This equipment has been tested and found to comply with the limits for a Class B digital device pursuant to Part 15 of the FCC Rules.

These limits are designed to provide reasonable protection against harmful interference in a residential installation. This equipment generates and can radiate radio frequency energy and, if not installed and used in accordance with the instructions, may cause harmful interference to radio communications. However, there is no guarantee that interference will not occur in a particular installation. If this equipment does cause harmful interference to radio or television reception, which can be determined by turning the equipment off and on, the user is encouraged to try to correct the interference by one or more of the following measures:

- Reorient or relocate the receiving antenna.
- Increase the separation between the equipment and receiver.

Connect the equipment into an outlet on a circuit different from where the receiver is connected.

## 27. OUTDOOR ANTENNA INSTALLATION/SAFE ANTENNA AND CABLE CONNECTION:

If an outside antenna or cable system is connected to the equipment, be sure the antenna or cable system is grounded so as to provide protection against built up static charges and voltage surges, Section 810 of the national Electrical Code, ANSI/NFP A70 (in Canada, part 1 of the Canadian Electrical Code) provides information with respect to proper grounding of the mast and supporting structure, grounding of the lead-in wire to an antenna discharge unit, size of grounding conductors, location of antenna discharge unit, connection to grounding electrodes and requirements for the grounding electrode.

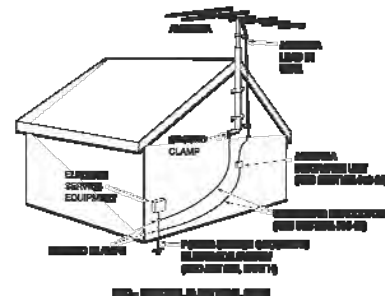

### Keep Antenna Clear of High Voltage Power Lines or Circuits

An outside antenna system should be located well away from power lines, electric light or power circuits and where it will never come into contact with these power sources if it should happen to fall. When installing an outside antenna, extreme care should be taken to avoid touching power lines, circuits or other power sources as this could be fatal. Because of the hazards involved, antenna installation should be left to a professional.

# WELCOME

---

## THANK YOU

Dear Customer:

We would like to thank you for your decision to buy a SLP 03 vacuum tube preamplifier. The SLP 03 combines the desirable attributes of low noise, low distortion and ease of use making it an excellent preamplifier choice for your home audio system. This stereo vacuum tube preamplifier offers one XLR balanced input pair and six pairs of RCA single-ended inputs making it a very capable preamplifier. The adjustable brightness front panel display shows the current settings and volume levels during use. The SLP 03, when combined with a power amplifier is capable of outstanding musical reproduction using your favorite music.

Thank you for your support and enjoy the music!

The Cary Audio Team

## PRODUCT OVERVIEW

The new Cary Audio Design SLP 03 preamplifier is a blend of digital computer technology and pure vacuum tube, analog discrete circuitry. The SLP 03 consists of actually four (4) analog, 16 dB, and line gain stages. Two separate gain stages are used for each of the two channels. One gain stage amplifies the positive phase (+180 degree) and the other gain stage amplifies the negative phase (-180 degree). Two stages for each channel equal the four active line circuits. All audio path signals are amplified through 12AU7 vacuum tubes in a class A zero feedback circuit.

The front panel display is a Noritake vacuum florescent display with a blue lens in front. The display receives and displays the critical control functions from a Motorola CPU incorporated inside the Cary Audio SLP 03 preamplifier. The Motorola processor is the controller for all functions of the preamplifier.

Back to the analog side of things, there are a total of eight (8) fully regulated power supplies in the SLP 03 preamplifier. Separate supplies for each channel's analog circuit along with multiple power supplies for the Alphanumeric, Noritake display, along with dual supplies for the Motorola processor. To power the fully regulated power supplies the SLP 03 has two individual R-Core shielded power transformers. Dual power transformers, along with separate left and right supplies, make the SLP 03 a true dual mono preamplifier. In fact, the channel separation is in excess of 80 dB. This amount of channel independence is a major engineering design breakthrough in vacuum tube designs.

A word about cinema-bypass is in order. We have discovered with previous Cary Audio preamplifier designs, when incorporating the cinema bypass that on occasion the user would forget that the system surround processor inputting to the preamp could be a very high level. Thus when the preamplifier power switch is placed in the off position, the default would be a feed through of the processor signal and could blast the left and right channel loudspeakers. In the SLP 03 the cinema-bypass only functions when the SLP 03 is powered up with the volume gain setting set at number 47 on the display. The reading of 47 is unity gain. It might be noted in the SLP 03 one could have a single ended (RCA) processor input and through the SLP 03 have a balanced output to the left and right channel amplifiers.

Operating the dual 12AU7 vacuum tubes in a current source configuration, true balanced output is achieved with both single-ended (RCA) inputs or the balanced (XLR) input selection.

# WELCOME

---

Considering the massive power transformers along with the multiple regulated supplies the SLP 03 will offer the ultimate sound reproduction when left on continuously 24/7. Tube life should be on the order of three years in the continuous duty mode.

The SLP 03, when combined with a solid state or vacuum tube power amplifier is capable of bringing outstanding musical reproduction into your home. The selected pair of dual triode 12AU7's vacuum tubes per channel offer true balanced vacuum tube warmth and realism. Convenience meets sound quality plus great industrial design in the Classic Series SLP 03 preamplifier.

## UNPACKING AND INSTALLATION

This section describes the unpacking and installation procedures for your new component.

### Unpacking

All Cary Audio Design shipping cartons have been specially designed to protect their contents and special care has been taken to prevent damage under normal shipping conditions. Mishandling should be evident upon inspection of the shipping container. If shipping damage is found after visual inspection, take care not to destroy the evidence. If necessary, document the damage with photographs and contact the transport carrier immediately.

Carefully remove your new component from its packing carton and examine it closely for signs of shipping damage. We strongly recommend saving all original packing cartons to protect your component from damage should you wish to store it or ship it at a later date.

### Warranty Card

If you are the original purchaser of this unit and you purchased it in the United States, you should fill out the enclosed warranty registration card and return it to Cary Audio Design within 15 days of your purchase. Cary Audio Design also suggests that you keep your original packing cartons in case you ever need to ship the unit when moving to a new home. Warranty restrictions apply. Consult the warranty section of this manual for details. Please be certain to keep a copy of the original sales receipt from your Authorized Cary Audio Design dealer to validate the warranty if ever needed. (Please review the limited warranty provisions on page 13).

# SPECIFICATIONS

---

The following section describes the unit's basic specifications. The specifications are subject to change without notice or obligation.

## BASIC SPECIFICATIONS

<b>Preamplifier Inputs</b>	1 pair balanced XLR connections 6 pair single-ended RCA connections
<b>Preamplifier Outputs</b>	1 pair balanced XLR connections 2 pair RCA connections
<b>Controller Connectors</b>	(1) 3.5mm "mini plug" jack for IR input (3) 3.5mm "mini plug" jack for trigger out RS 232 full remote configuration interface
<b>Vacuum Tube Compliment</b>	(4) 12 AU7 dual triode tubes
<b>Volume Control Range</b>	63.0 dB
<b>Gain</b>	16 dB
<b>Input Impedance</b>	100 k Ohms on RCA 200 k Ohms on XLR
<b>Output Impedance</b>	500 Ohms on XLR 500 Ohms on RCA
<b>Rated Output</b>	RCA - 1 Volt (8 volts maximum) XLR - 2 Volts (16 volts maximum)
<b>THD+N</b>	<0.03%
<b>Frequency Response</b>	±0.5 dB from 5 Hz to 50 kHz
<b>Residual Noise</b>	<90 dB
<b>Power Input</b>	110/117 or 220/234 Volts AC @ 50-60 Hz
<b>Power Consumption</b>	75 watts
<b>Weight</b>	25 lbs.
<b>Dimensions</b>	4.5" H x 17" W x 13" D



# OPERATION

---

Operating this component is a simple procedure. Each unit is designed for long term stability in virtually any home operating situation. However, if the unit is operated outside the parameters outlined in this owner's manual, damage may result. Please read this manual carefully before putting your new unit into operation.

## CONNECTIONS

Balanced Inputs:	Accepts right-channel and left-channel balanced signals from a source component with balanced outputs.
Single-ended Inputs:	Accepts right-channel and left-channel (single-ended) RCA connection inputs from a source component.
Balanced Main Outputs:	These are for connection to the XLR input jacks of an accompanying power amplifier or electronic crossover.
Single-ended Outputs:	These are for connection to the RCA input jacks of an accompanying power amplifier or electronic crossover.

## CHECKING CONNECTIONS

1. Make sure that all the connections are proper by referring to the rear panel labels.
2. Check the directivity of stereo separation (right channel to right channel, left channel to left channel).
3. Check the directivity of pin cord connection, if your patch cables are labeled for direction of connection.

## SWITCHING ON

### POWER button

- Press once to turn the power ON.
- Press again to set to the OFF position and turn the power off. The SLP 03 will enter into Standby and the blue LED will light.

### SOURCE SELECT buttons

- Press once to select the desired input source.

### VOLUME knob

- Turn the volume knob to the desired listening level.

### BREAKING-IN

- The SLP 03 requires at least 100 hours of continuous operation after it is first turned on to sound its best. This gives the materials in various circuit components a chance to "form" so audio signals achieve greater definition, smoothness and transparency. Although the unit will sound spectacular when you first operate it, it will improve in sound quality as it completes the "burn in" of the vacuum tubes. This is normal for new vacuum tubes. During the vacuum tube manufacturing process, the insides are coated with special compounds designed to burn off with heat to finish making the vacuum inside the tube. This is why the "burn in" process is necessary when using new tubes.

# CONTROLS AND DISPLAYS

## FRONT PANEL

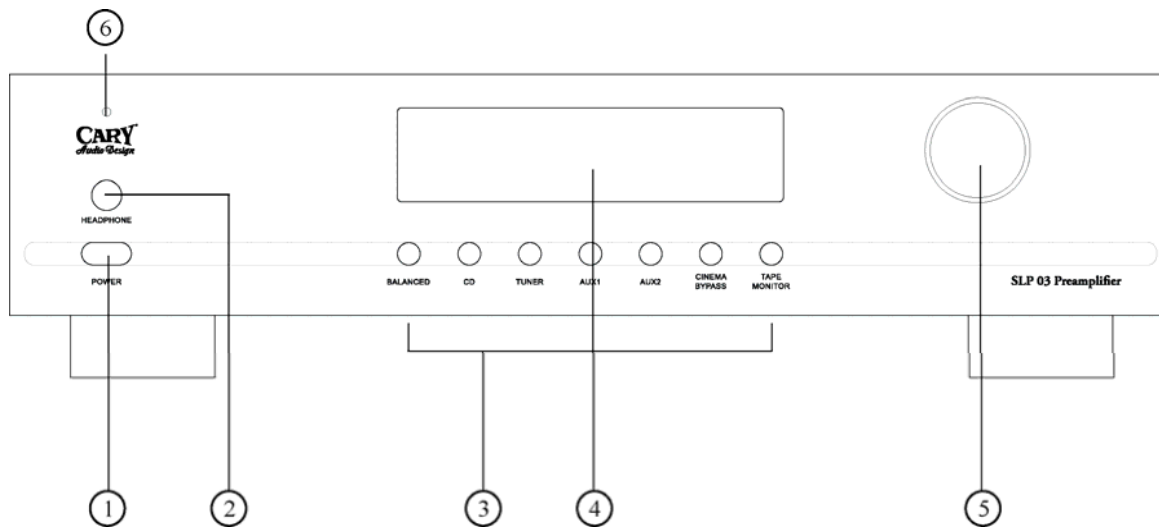

### 1. POWER

- Press once to turn the power ON.
- Press again to turn the power OFF. The amplifier will enter STANDBY and the blue POWER LED will light.

### 2. HEADPHONE JACK

- This jack is used to listen to headphones.

### 3. SOURCE SELECTOR

- The input source is selected by pressing the respective buttons.

### 4. ALPHANUMERIC Display

- This thirteen-character display provides a wide range of information concerning the operation of the SLP 03. The information displayed depends on what the SLP 03 is doing.
- The information displayed is summarized below:  
Normal Operation: Displays the selected input name and volume setting.  
Balance Mode: This shows the direction (L or R) and magnitude of the balance offset, from channel to channel.

### 5. VOLUME

- Use the volume control to adjust the listening level.

### 6. POWER INDICATOR (Standby)

- This indicator lights when the amplifier is switched into standby mode.

# CONTROLS AND DISPLAYS

## REAR PANEL

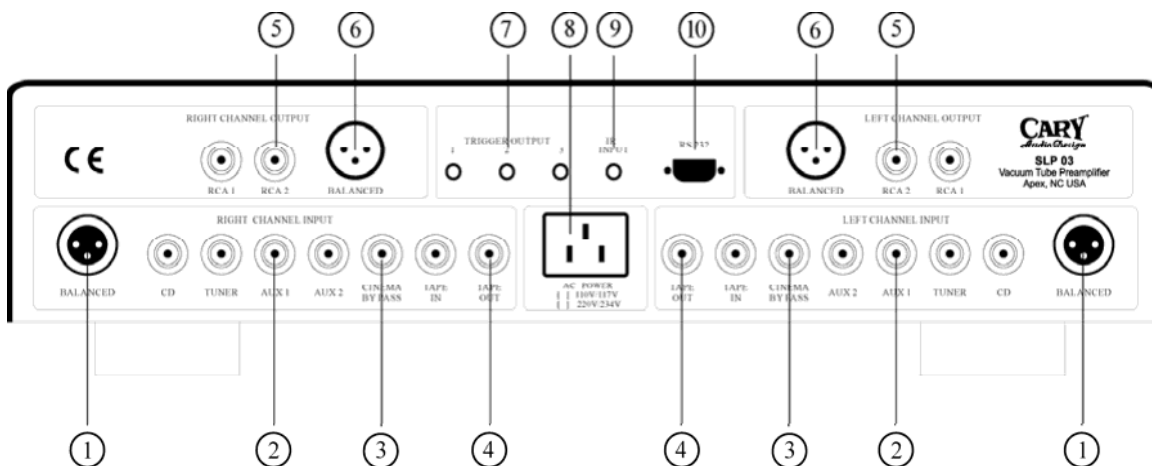

### 1. BALANCED INPUTS

- Accepts right-channel and left-channel balanced signals from source equipment with balanced outputs.
- The pin assignments of these XLR-type female input are:



- Pin 1: Signal ground
- Pin 2: Signal + (non-inverting)
- Pin 3: Signal - (inverting)
- Connector ground lug: chassis ground

Refer to the operating manuals of your balanced-output line-level sources to verify that the pin assignments of their output connectors correspond to the SLP 03. If not, wire the cable so that the appropriate output pin connects to the equivalent input pin.

### 2. SINGLE-ENDED INPUTS

- Accepts right-channel and left-channel (RCA) inputs from line-level source equipment such as tuners, CD player or SACD player.

### 3. CINEMA BYPASS

- Designed to accept the left and right main channel from a surround processor to drive the left and right amplifier system amplifiers. The proper setting of the SLP 03 volume level should be set to number 47 on the front display of the SLP 03. The number 47 is where unity gain occurs. With the SLP 03 set to Cinema Bypass input mode and the volume at number 47 on the display the processor will now operate through the SLP 03 to control the left and right channels.

### 4. ANALOG RECORD OUTPUT JACK (RCA UNBALANCED)

- Use these jacks for connection to the right-channel and left-channel tape inputs of your tape or hard drive based recorder.

### 5. SINGLE-ENDED MAIN OUTPUTS

- Use these jacks for connection to the power amplifiers.

# CONTROLS AND DISPLAYS

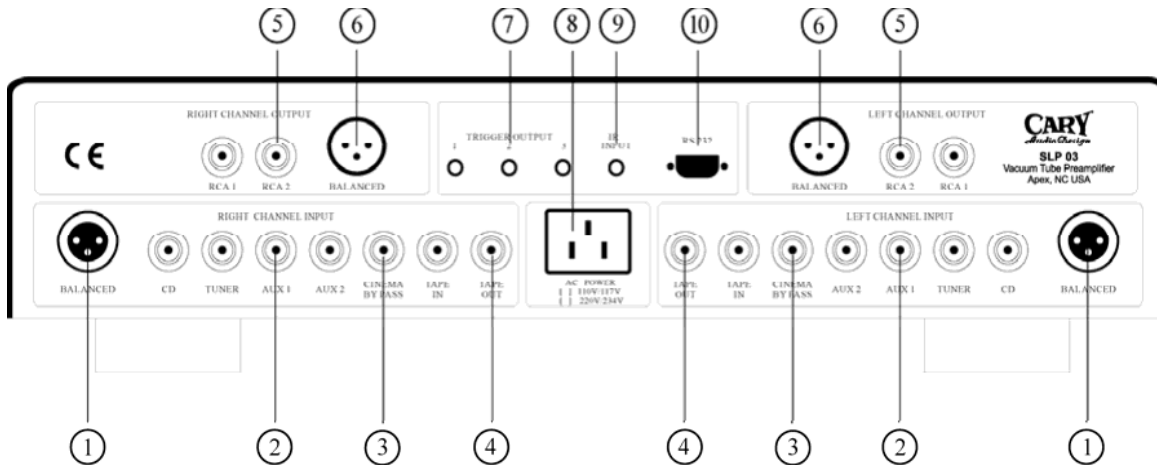

## 6. BALANCED MAIN OUTPUTS

- If your power amplifier is equipped with balanced inputs, it is generally best to use the balanced outputs on your preamplifier. A balanced signal from preamplifier to power amplifier will offer the highest possible performance with the best immunity from common-mode noise, such as radio frequency interference (RFI). The balanced output signal is made available by way of precision male XLR connectors (requiring female XLRs on the preamplifier end of the interconnecting cable).
- The pin assignments of these XLR-type male outputs are:

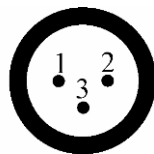

- Pin 1: Signal ground
- Pin 2: Signal + (non-inverting)
- Pin 3: Signal - (inverting)
- Connector ground lug: chassis ground

Refer to your power amplifier's operating manual to verify that the pin assignments of its input connectors correspond to the SLP 03. If not, wire the cable so that the appropriate output pin connects to the equivalent input pin.

## 7. DC TRIGGER OUTPUT TERMINALS

- Connect a device that needs to be triggered by DC + 12V. (CD player)

## 8. POWER INPUT (AC IN)

- Connect to an AC power supply using the included power supply cord.

## 9. IR INPUT JACK

- Use this jack to connect external IR sensors.

## 10. RS-232 PORT

- The RS-232 port is used in conjunction with an external controller to control the operation of the SLP 03. (This is for custom installation use. Consult your dealer for more information.)

# CONTROLS AND DISPLAYS

## REMOTE CONTROL

This section explains how best to use the remote control to operate the SLP 03.

1. **POWER:** Use to turn the power on and off.
2. **MUTE:** Use to mute the sound. Press again to resume sound.
3. **INPUT SELECTOR:** Use the buttons for remote selection of the various inputs of the SLP 03.
4. **VOLUME:** Use the buttons to adjust the volume of the SLP 03 from Volume 0 to Volume 63.
5. **BALANCE:** Use the buttons to fine-tune the relative balance of the Left and Right channel from your listening position using the balance buttons in 1 dB increments..

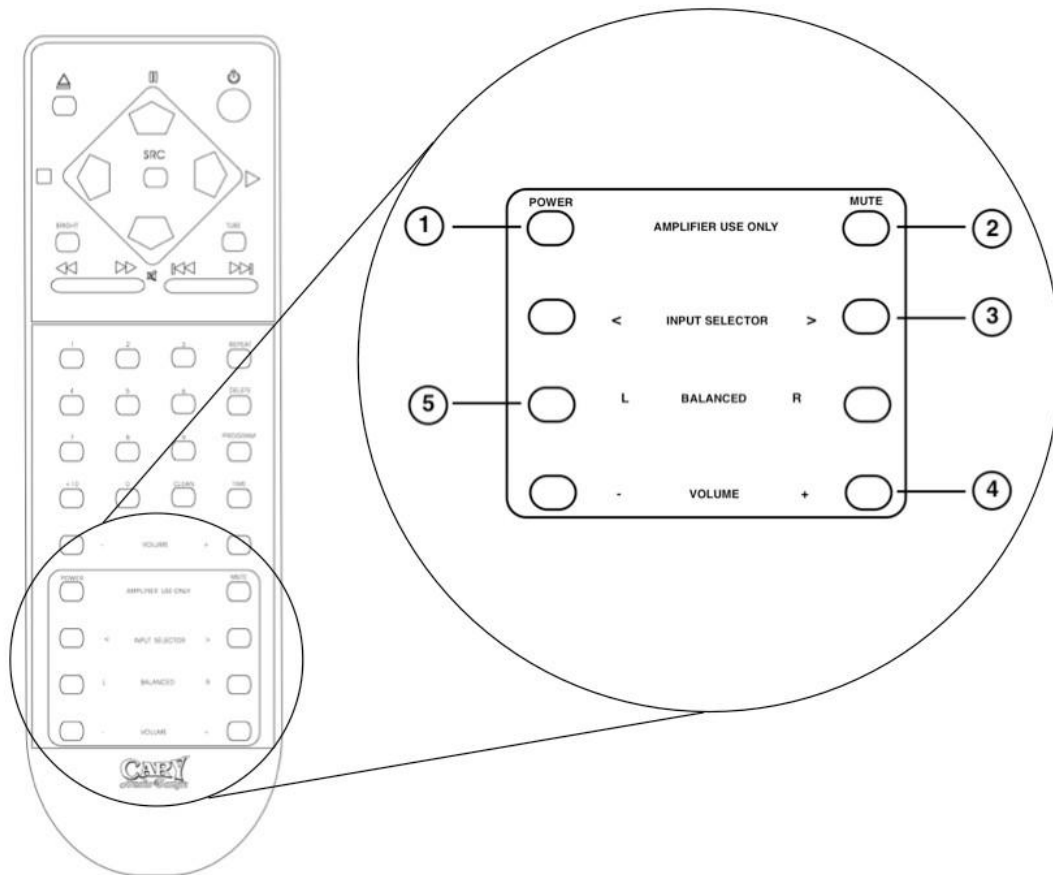

# SERVICE AND CARE

---

## CARE AND CLEANING

The cabinet housing and front panel of the component may be cleaned with a soft cloth and Windex or a window cleaner. The frequency of cleaning will be governed by how many hours the unit is operated and by the cleanliness of the operating environment.

## FACTORY SERVICE

Careful consideration has been given to the design of this component to keep maintenance problems to a minimum. Any problems or requests for service should be referred to our Customer Service Department at 919-355-0010. DO NOT return the unit to the factory without a return authorization number (RA) from the Customer Service Department.

Cary Audio Design will assume no responsibility if the shipping company refuses to pay for damage due to your improper packing or lack of insurance should the unit be lost or damaged in shipment. Please retain and always use the original shipping carton for shipping the player.

## NON-WARRANTY REPAIRS

Cary Audio Design will provide repair service for its products charging on a time and expense basis. At this time, the standard non warranty service bench fee is \$125 with all parts used for repair charged extra. This may change and is not a quote for service. Please call us at 919-355-0010 for more information about out of warranty service and repair fees.

**CAUTION:**

- Never remove or insert the back panel AC plug when the unit is on or the AC cord is plugged into the wall.

# LIMITED WARRANTY

---

## **Cary Audio Warrants to the original United States purchaser for use in the United States the Following Cary Audio Products for the Periods Indicated:**

1. Power Amplifiers, Integrated Amplifiers, Surround Sound Processors, and Preamplifiers have a three (3) year parts and labor warranty from the date of the original purchase from Cary Audio.
2. CD or SACD players, DVD players, or Music Servers have an eighteen (18) month parts and labor warranty from the date of the original purchase from Cary Audio.
3. Vacuum tubes, if any are used in the component, are offered a 90-day exchange policy against defects with the exception of the CAVT 300B vacuum tube that has a one (1) year exchange policy from the date of the original purchase from Cary Audio.

## **What is Covered and What is Not Covered**

Except as specified below, this warranty covers parts and labor to correct all defects in materials and workmanship. The following are not covered by the warranty:

1. Damage, deterioration, malfunction or failure to meet performance specifications resulting from:
  - a. Accident, acts of nature, misuse, abuse, neglect or unauthorized product modifications
  - b. Improper installation, removal or maintenance, or failure to follow instructions supplied with the product.
  - c. Repair or attempted repair by anyone not authorized by Cary Audio to repair the product.
  - d. Any shipment of the product (claims must be presented to the carrier).
  - e. Any cause other than a product defect.
2. Cleaning, initial set-up, check-ups with no defects found, or charges incurred for installation, removal or reinstallation of the product.
3. Any product, on which the serial number has been defaced, modified or removed.
4. Batteries.
5. Accessories, including but not limited to, batteries, cables, mounting hardware and brackets, cleaning accessories, antenna and detachable power cords.
6. Warranty is void if purchase was made from anyone other than an authorized Cary Audio dealer.

## **Who May Enforce the Warranty?**

This warranty extends to products purchased directly from Cary Audio or an authorized Cary Audio dealer. Purchasers should inquire of the dealer regarding the nature and extent of the dealer's warranty, if any.

To obtain such warranty service, the original purchaser must complete and send in the Warranty Registration Card within 15 days of purchase.

# LIMITED WARRANTY

---

## What Will We Pay For?

We will pay for all labor and material expenses for items covered by the warranty. Payment of shipping charges is discussed in the next section of this warranty.

## How You Can Get Service?

In the event that the owner needs to return the unit to Cary Audio for service or repair of a possible defect, he must follow the following steps:

1. Contact Cary Audio at 919-355-0010 to obtain a Return Merchandise Authorization (RMA) number prior to shipping; include this number with the package
2. Submit a copy of the original sales receipt; blank receipts will not validate the limited warranty for service by Cary Audio. The original sales receipt must contain the following information:
  - a. The authorized Cary Audio dealer's name
  - b. The date of purchase
  - c. The unit's sales price
  - d. The buyer's name and address
  - e. Describe in detail the problem.
  - f. Note the unit's model number and serial number.
3. Deliver by either of these methods:
  - a. With all freight and insurance charges prepaid and in its original packing container or equivalent, ship the component to Cary Audio, 1020 Goodworth Drive Apex, NC 27539.
  - b. Hand-deliver the product to Cary Audio (address noted above) or the nearest authorized service facility.

## Limitation of Implied Warranties

All implied warranties, including warranties of merchantability and fitness for particular purchase, are limited in duration to the length of this warranty.

## Exclusion of Damages

Cary Audio's liability for any defective product is limited to repair or replacement of the product at Cary Audio's option. Cary Audio shall not be liable for damage to other products caused by any defects in Cary Audio products, damages based upon inconvenience or loss of use of the product, or any other damages, whether incidental, consequential, or otherwise.

## How State Law Relates to the Warranty

Some states do not allow limitations on how long an implied warranty lasts and/or do not allow the exclusion or limitation of incidental or consequential damages, so the above limitations or exclusions may not apply to you.



## **LIMITED WARRANTY**

---

This warranty gives you specific legal rights, and you may also have other rights which vary from state to state.

### **International Purchasers (Export Markets)**

Cary Audio warrants its merchandise to purchasers within the United States exclusively for use within the United States. It provides no other warranties, expressed or implied. If you are living outside of the United States, please consult your local dealer or distributor to determine the details of your local warranty.

**CARY AUDIO DESIGN**

1020 Goodworth Drive, Apex, NC 27539  
phone 919-355-0010  
fax 919-355-0013  
[www.caryaudio.com](http://www.caryaudio.com)