



# Model 2.125

Full Balanced Power Amplifier

## OWNER'S MANUAL

NOTE: Before installing your new component, please read this manual carefully as it will inform you of the product specifications, proper installation and correct operating procedures for your unit. Also included in this manual are guidelines on how to service and care for your new Cary Audio Design product.

# TABLE OF CONTENTS

---

<b>Important Safety Instructions</b> .....	2-4
<b>Welcome</b>	
Thank You .....	5
Unpacking and Installation .....	5
<b>Specifications</b>	
Basic Specifications .....	6
<b>Operation</b>	
Connections .....	7
Switching On .....	7
<b>Controls &amp; Displays</b>	
Front Panel .....	8
Rear Panel .....	9-10
<b>Service and Care</b>	
Care and Cleaning .....	11
Factory Service .....	11
Non-Warranty Repairs .....	11
<b>United States Limited Warranty</b> .....	12

# IMPORTANT SAFETY INSTRUCTIONS

---

**WARNING:** To reduce the risk of fire or electric shock, do not expose this appliance to rain or moisture. The lightning flash with arrowhead symbol within an equilateral triangle is intended to alert the user to the presence of un-insulated dangerous voltage within the product's enclosure that may be of sufficient magnitude to constitute a risk of electric shock to persons.

**CAUTION:** To reduce the risk of electric shock, do not remove the cover. There are no user serviceable parts inside. Please refer to qualified personnel for service.

**ALERT:** The exclamation point within an equilateral triangle is intended to alert the user of the presence of important operating and maintenance (servicing) instructions in the literature accompanying the component.

1. **READ ALL INSTRUCTIONS:** All the safety and operating instructions of your Cary Audio equipment should be read before power is applied to the equipment.
2. **RETAIN OWNER'S MANUAL:** These safety and operating instructions should be retained for future reference.
3. **HEED WARNING:** All warnings on the unit and in the operating instructions should be adhered to.
4. **FOLLOW INSTRUCTIONS:** All operating and use instructions should be followed.
5. **CLEANING:** Unplug the unit from the wall outlet before cleaning. The unit should be cleaned only as recommended by the manufacturer.
6. **ATTACHMENTS:** Do not use attachments not recommended by the unit manufacturer as they may cause hazards.
7. **WATER AND MOISTURE:** Do not use the unit near water - for example, near a bath tub, wash bowl, kitchen sink, or laundry tub; in a wet basement; or near a swimming pool.
8. **ACCESSORIES:** Do not place the unit on an unstable cart, stand, tripod, bracket, or table. The unit may fall, causing serious injury to a child, an adult, or damage to the unit. Mounting of the unit should follow the manufacturer's instructions and should use a mounting accessory recommended by the manufacturer.
9. **VENTILATION:** Slots and openings in the cabinet are provided for ventilation to ensure reliable operation of the unit and to protect it from overheating. These openings must not be blocked or covered. The top or bottom panel openings should never be blocked by placing the unit on a bed, sofa, rug, or other similar surface. The unit should not be installed in a built-in location such as a bookcase or rack unless proper ventilation is provided. There should be free space of at least 6 inches (16cm) above the unit and an opening behind the unit.
10. **GROUNDING OR POLARIZATION:** The unit may be equipped with a polarized alternating current line plug (a plug having one blade wider than the other). This plug will fit into the power outlet only one way. This is a safety feature. If you cannot insert the plug fully into the outlet, try reversing the plug. If the plug should fail to fit, contact a licensed electrician to replace your obsolete outlet. Do not defeat the safety purpose of the polarized plug.
11. **POWER SOURCES:** The unit should be operated only from the type of power source indicated on the marking label. If you are not sure of the type of power supplied to your home, consult your unit dealer or local power company.
12. **POWER CORD PROTECTION:** Power supply cords should be routed so that they are unlikely to be walked on or pinched by items placed on or against them. Pay close attention to cords where they enter a plug, or a convenience receptacle, and the point where they exit from the unit.
13. **OUTDOOR ANTENNA GROUNDING:** If an outside antenna or cable system is connected to the unit, be sure the antenna or cable system is grounded so as to provide protection against voltage surges and built-up static charges. Article 810 of the National Electrical Code, NSI/NFPA 70, provides information regarding proper grounding of the mast and supporting structure, grounding of the lead-in wire to an Antenna-discharge unit, size of grounding conductors, location of antenna-discharge unit, connection to grounding electrodes, and requirements for the grounding electrode.

# IMPORTANT SAFETY INSTRUCTIONS

---

14. **LIGHTNING:** For added protection for the unit during a lightning storm, or when it is left unattended and unused for long periods of time, unplug it from the wall outlet and disconnect the antenna or cable system. This will prevent damage to the unit due to lightning and power line surges.
15. **POWER LINES:** An outside antenna system should not be located in the vicinity of overhead power lines or other electric light or power circuits, or where it can fall into such power lines or circuits. When installing an outside antenna system, take extreme care to keep from touching such power lines or circuits as contact with them might be fatal.
16. **OVERLOADING:** Do not overload wall outlets, extension cords, or integral convenience receptacles as this can result in a risk of fire or electric shock.
17. **OBJECT AND LIQUID ENTRY:** Never push objects of any kind into the unit through openings as they may touch dangerous voltage points or short-out parts that could result in a fire or electric shock. Never spill liquid of any kind on the unit.
18. **SERVICING:** Do not attempt to service the unit yourself as opening or removing covers may expose you to dangerous voltage or other hazards. Refer all servicing to qualified service personnel.
19. **REPLACEMENT PARTS:** When replacement parts are required, be sure the service technician has used replacement parts specified by the manufacturer or have the same characteristics as the original part. Unauthorized substitutions may result in fire, electric shock or other hazards.
20. **SAFETY CHECK:** Upon completion of any service or repairs to the unit, ask the service technician to perform safety checks to determine that the unit is in proper operating condition.
21. **WALL OR CEILING MOUNTING:** The unit should be mounted to a wall or ceiling only as recommended by the manufacturer.
22. **HEAT:** The unit should be situated away from heat sources such as radiators, heat registers, stoves, or other units (including amplifiers) that produce heat.
23. **IMPORTANT SAFETY NOTE:** Before connecting a new component to your audio or home theater system it is always good practice to make certain that all components are turned off, and preferably unplugged from their AC power source. Many modern electronics products feature automatic turn-on circuits that may be activated during an installation, causing the potential for damage to electronic components and/or speakers. Such damage is not covered by product warranties and Cary Audio specifically disclaims responsibility for any such damage.  
  
**Power Cord:** The removable power cord that is shipped with the player is specifically designed to be used with this product. Other AC cords may be used, so consult your dealer for advice on AC power cords and high quality wire in your system.  
  
**AC Fuse:** The fuse is located inside the chassis and is not user serviceable. If power does not come on, contact your authorized service representative.  
  
**Wiring:** Cables that run inside of walls should have the appropriate markings to indicate compliance with, and listing by the UL, CSA or other standards required by the UL, CSA, NEC or your local building code. Questions about cables inside of walls should be referred to a qualified custom installer, or a licensed electrician or low-voltage contractor.  
  
**Do Not Open the Cabinet:** There are no user serviceable components inside this product. Opening the cabinet may present a shock hazard, and any modification to the product will void your warranty. If water or any metal object, such as a paper clip, coin, or staple accidentally falls inside the unit, disconnect it from the AC power source immediately and contact Cary Audio for further instructions.
24. **RECORDING COPYRIGHT:** Recording of copyrighted material for other than personal use is illegal without permission of the copyright holder.
25. **NOTE TO CATV SYSTEM INSTALLER:** This reminder is provided to call the CATV system installer's attention to article 820-40 of the NEC, ANSI/NFPA 70, which provides guidelines for proper grounding and, in particular, specifies that the cable ground shall be connected to the grounding system of the building, as close to the point of cable entry as practical.

# IMPORTANT SAFETY INSTRUCTIONS

---

## 26. FCC INFORMATION FOR USER:

**CAUTION:** ANY changes or modifications not expressly approved by the party responsible for compliance could void the user's authority to operate the equipment.

**NOTE:** This equipment has been tested and found to comply with the limits for a Class B digital device pursuant to Part 15 of the FCC Rules.

These limits are designed to provide reasonable protection against harmful interference in a residential installation. This equipment generates and can radiate radio frequency energy and, if not installed and used in accordance with the instructions, may cause harmful interference to radio communications. However, there is no guarantee that interference will not occur in a particular installation. If this equipment does cause harmful interference to radio or television reception, which can be determined by turning the equipment off and on, the user is encouraged to try to correct the interference by one or more of the following measures:

- Reorient or relocate the receiving antenna.
- Increase the separation between the equipment and receiver.

Connect the equipment into an outlet on a circuit different from where the receiver is connected.

27. **OUTDOOR ANTENNA INSTALLATION/SAFE ANTENNA AND CABLE CONNECTION:** If an outside antenna or cable system is connected to the equipment, be sure the antenna or cable system is grounded so as to provide protection against built up static charges and voltage surges, Section 810 of the national Electrical Code, ANSI/NFP A70 (in Canada, part 1 of the Canadian Electrical Code) provides information with respect to proper grounding of the mast and supporting structure, grounding of the lead-in wire to an antenna discharge unit, size of grounding conductors, location of antenna discharge unit, connection to grounding electrodes and requirements for the grounding electrode.

### **Keep Antenna Clear of High Voltage Power Lines or Circuits**

An outside antenna system should be located well away from power lines, electric light or power circuits and where it will never come into contact with these power sources if it should happen to fall. When installing an outside antenna, extreme care should be taken to avoid touching power lines, circuits or other power sources as this could be fatal. Because of the hazards involved, antenna installation should be left to a professional.

# WELCOME

---

## THANK YOU

Dear Customer:

We would like to thank you for your decision to buy a Concept Series Model 2.125 power amplifier. The Model 2.125 power amplifier design offers high output power and high efficiency in an attractive small chassis. The Model 2.125 is rated at 125 watts per channel into an 8 ohm load and it is capable of doubling the output power to 250 watts into a 4 ohm load. This type of performance is only possible with rugged, over designed power supplies. The output terminals are designed for bi-wire operation. High efficiency and excellent musicality with cool running ICE™ modules are all great design aspects of the Model 2.125 power amplifier.

Thank you for your support and enjoy the music!

The Cary Audio Team

## UNPACKING AND INSTALLATION

This section describes the unpacking and installation procedures for your new component.

### Unpacking

All Cary Audio Design shipping cartons have been specially designed to protect their contents and special care has been taken to prevent damage under normal shipping conditions. Mishandling should be evident upon inspection of the shipping container. If shipping damage is found after visual inspection, take care not to destroy the evidence. If necessary, document the damage with photographs and contact the transport carrier immediately.

Carefully remove your new component from its packing carton and examine it closely for signs of shipping damage. We strongly recommend saving all original packing cartons to protect your component from damage should you wish to store it or ship it at a later date.

### Warranty Card

If you are the original purchaser of this unit and you purchased it in the United States, you should fill out the enclosed warranty registration card and return it to Cary Audio Design within 15 days of your purchase. Cary Audio Design also suggests that you keep your original packing cartons in case you ever need to ship the unit when moving to a new home. Warranty restrictions apply. Consult the warranty section of this manual for details. Please be certain to keep a copy of the original sales receipt from your Authorized Cary Audio Design dealer to validate the warranty if ever needed.

# SPECIFICATIONS

---

The following section describes the Model 2.125's basic specifications. The specifications are subject to change without notice or obligation.

## BASIC SPECIFICATIONS

<b>Inputs</b>	1 pair balanced XLR connections 1 pair RCA connections
<b>Input Sensitivity</b>	0.7 V (full-rated output)
<b>Controller Connectors</b>	(1) 3.5mm "mini plug" jack for trigger input (4) custom speaker binding posts
<b>Input Impedance</b>	100 k Ohms on RCA 200 k Ohms on XLR
<b>Rated Power Output</b>	125 watts/channel rms. @ 8 Ohms 250 watts/channel rms. @ 4 Ohms
<b>Rated THD</b>	0.2%
<b>Frequency Response</b>	±0.5 dB from 20 Hz to 50 kHz
<b>Damping Factor</b>	> 1,000 20-20,000 Hz
<b>Signal-to-Noise Ratio</b>	-80 dB CCIR
<b>Voltage Gain</b>	27.2 dB
<b>Power Input</b>	110/117 or 220/234 Volts AC @ 50-60 Hz
<b>Power Consumption</b>	450 watts – Operation 50 watts – Idle 0.5 watts - Standby
<b>Weight</b>	20 lbs.
<b>Dimensions</b>	4.5" H x 17" W x 13" D

# OPERATION

---

Operating this component is a simple procedure. Each unit is designed for long term stability in virtually any home operating situation. However, if the unit is operated outside the parameters outlined in this owner's manual, damage may result. Please read this manual carefully before putting your new component into operation.

## CONNECTIONS

- Balanced Inputs: Accepts right-channel and left-channel balanced signals from the preamplifier with balanced outputs.
- Single-ended Inputs: Accepts right-channel and left-channel (single-ended) inputs from the preamplifier.
- Loudspeaker Binding Posts: Connect + (positive) binding post on the Model 2.125 to the positive inputs on the associated loudspeaker.  
Connect – (negative) binding post on the Model 2.125 to the negative inputs on the associated loudspeaker.

## SWITCHING ON

### POWER button

- Press once to turn the power "ON".
- Press again to set to the "OFF" position and turn the power off. The amplifier will enter into Standby and the blue LED will light.

### POWER ON indicator

- The backlit etched Crystal 3D logo lights when the power amplifier is turned ON.

### STANDBY indicator

- The indicator lights when the power amplifier is switched to standby mode.

### BREAKING-IN

- The Model 2.125 requires at least 100 hours of continuous operation after it is first turned on to sound its best. This gives the materials in various circuit components a chance to "form" so audio signals achieve greater definition, smoothness and transparency.

Although the unit will sound spectacular when you first operate it, you will find it worthwhile to listen again after a few days and you'll discover details in your music you may not have noticed were there.



# CONTROLS AND DISPLAYS

## FRONT PANEL

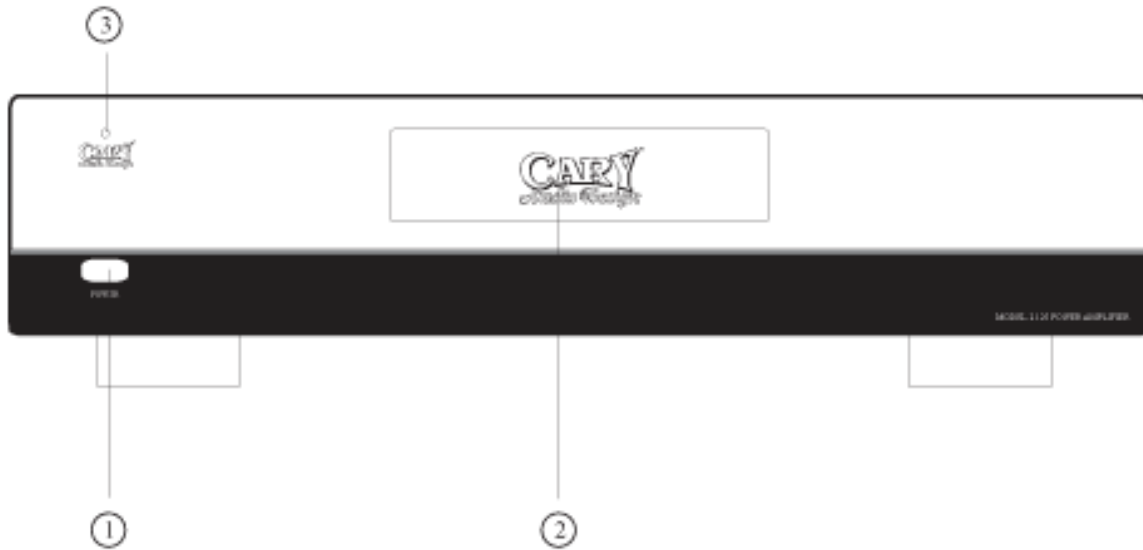

### 1. POWER button

- Press once to turn the power "ON".
- Press again to set to the "OFF" position and turn the power off. The amplifier will enter into Standby and the blue LED will light.

### 2. POWER ON indicator

- The backlit etched Crystal 3D logo lights when the power amplifier is turned ON.

### 3. STANDBY indicator

- The indicator lights when the power amplifier is switched to standby mode.

# CONTROLS AND DISPLAYS

## REAR PANEL

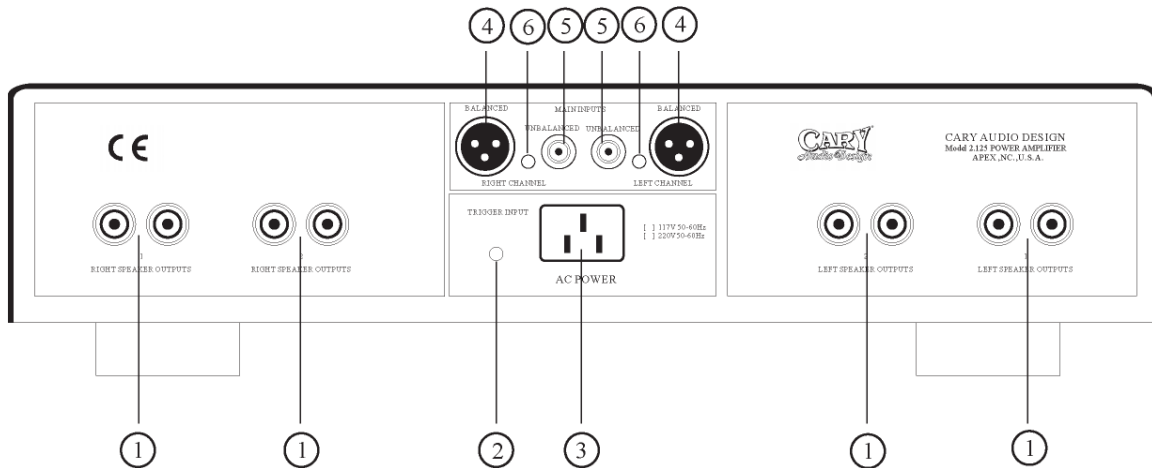

### 1. LOUDSPEAKER BINDING POSTS (OUTPUTS)

- Provide audio output. Two pair of custom-made, high-current Cardas binding posts labeled + (positive) and - (negative) are included.
- These binding posts are designed to facilitate high pressure, high contact area connections without the use of tools such as nut drivers. A simple finger-tightening actually yields higher contact pressure than traditional hex binding posts. There is no need to exert unusual effort when tightening.
- **CAUTION!**  
NEVER connect power amplifier outputs to any component other than a loudspeaker.  
NEVER short-circuit power amplifier outputs.  
NEVER connect power amplifier outputs to another power amplifier's outputs.  
DO NOT OVERTIGHTEN the Model 2.125 binding posts. Tight, high-contact pressure connections can be achieved with finger-tightening.  
DO NOT FORCE the Model 2.125 binding post "wings" up and over a bent or oversized connector. Doing so may result in binding post damage. If the connector obstructs "wing"-turning, slide it into place when the binding post opening provides a snug fit. Then, use quarter-turns to tighten the connection as needed.

### 2. DC TRIGGER INPUT TERMINALS

- Provide DC trigger control. One 3.5mm mini-jack is available to receive 12V DC signals from a connected component. Toggling the connected component between ON and STANDBY will toggle the Model 2.125 into and out of STANDBY.

### 3. POWER INPUT (AC IN)

- Connect to an AC power supply using the included power supply cord.

# CONTROLS AND DISPLAYS

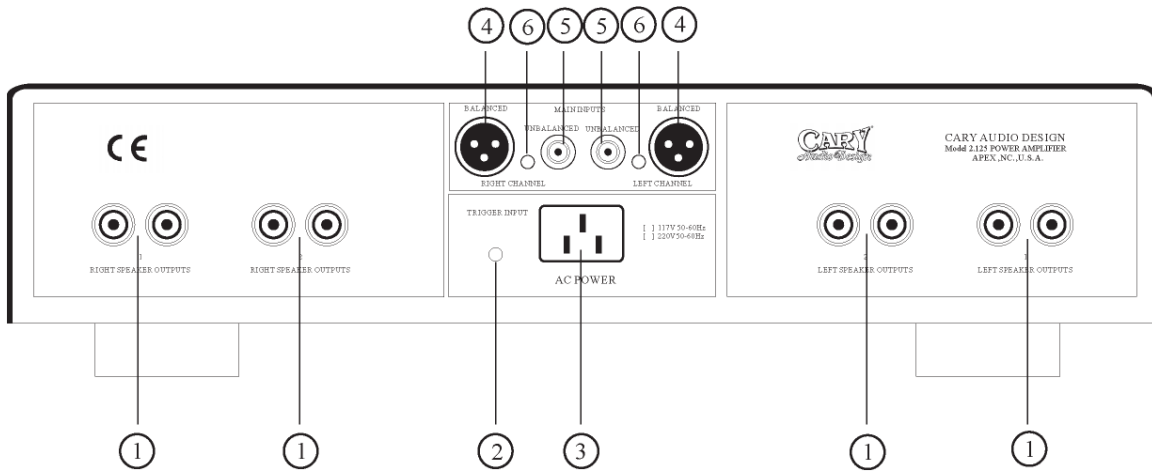

## 4. BALANCED INPUTS

- Accepts right-channel and left-channel balanced signals from the associated preamplifier with balanced outputs.
- The pin assignments of these XLR-type female input are:

Pin 1: Signal ground

Pin 2: Signal + (non-inverting)

Pin 3: Signal - (inverting)

Connector ground lug: chassis ground

Refer to your preamplifier's operating manual to verify that the pin assignments of its input connectors correspond to this unit. If not, wire the cable so that the appropriate output pin connects to the equivalent input pin.

## 5. SINGLE-ENDED INPUTS

- Accepts right-channel and left-channel (RCA) inputs from the preamplifier. These signals are converted to balanced signals upon entering the chassis and processed as balanced signals thereafter. One pair RCA connector is available.

## 6. INPUT SWITCH

- Use this switch to choose between the BALANCED inputs or the SINGLE-ENDED inputs.

# SERVICE AND CARE

---

## CARE AND CLEANING

The cabinet housing and front panel of this unit may be cleaned with a soft cloth and Windex or a window cleaner. The frequency of cleaning will be governed by how many hours the component is operated and by operating environment cleanliness.

## FACTORY SERVICE

Careful consideration has been given to the design of this component to keep maintenance problems to a minimum. Any problems or requests for service should be referred to our Customer Service Department at 919-355-0010. DO NOT return the unit to the factory without a return authorization number (RA) from the Customer Service Department.

Cary Audio Design will assume no responsibility if the shipping company refuses to pay for damage due to your improper packing or lack of insurance should the unit be lost or damaged in shipment. Please retain and always use the original shipping carton for shipping the player.

## NON-WARRANTY REPAIRS

Cary Audio Design will provide repair service for its products charging on a time and expense basis. At this time, the standard non warranty service bench fee is \$125 with all parts used for repair charged extra. This may change and is not a quote for service. Please call us at 919-355-0010 for more information about out of warranty service and repair fees.

**CAUTION** - Never remove or insert the back panel AC plug when the unit is on or the ac cord is plugged into the wall.

# UNITED STATES LIMITED WARRANTY

---

Cary Audio Design warrants to the original United States purchaser for use in the United States that Cary Audio Design vacuum tube or solid state power amplifiers, surround sound processors or preamplifiers shall be free from defects in parts or workmanship for three (3) years from the date of the original purchase. Vacuum tubes, if any are used in the component, are offered a 90 day from purchase date exchange policy against defects with the exception of the CAVT 300B vacuum tube which has a (1) one year from purchase date exchange policy. Any digital drive design, whether a Cary Audio Design CD or SACD player or a Cary Cinema DVD player, has a limited one year parts and labor warranty against defects in manufacture. This is a limited warrant, for the original purchaser only and does not transfer to any subsequent owner.

During the limited warranty period, Cary Audio Design or an authorized Cary Audio Design service facility will provide free of charge both parts and labor necessary to correct any defects in material or workmanship.

To obtain such warranty service, the original purchaser must:

1. Complete and send in the warranty Registration Card within 15 days of purchase.
2. If claiming service the owner must send a fully filled in copy of the original sales receipt along with any unit sent in for service showing the AUTHORIZED CARY AUDIO DESIGN DEALER'S name, the new selling price, the buyer's name, e-mail or phone number and address on the receipt. Blank receipts will NOT validate the limited warranty for service.
3. Notify Cary Audio Design as soon as possible after the discovery of a possible defect and submit the following information to determine eligibility for warranty:
  - (a) The model number and serial number;
  - (b) A fully filled in copy of the original sales receipt showing the original selling price, purchasers name and address filled in by an AUTHORIZED CARY AUDIO DESIGN DEALER with the original date of purchase shown on the form;
  - (c) a detailed description of the problem.
4. Deliver the product to Cary Audio Design or the nearest authorized service facility or ship with all freight and insurance charges prepaid, in its original packing container or equivalent, to Cary Audio.

Correct maintenance, repair and use are important to obtain performance from this product. Therefore, please carefully read the Operating Manual. This warranty does not apply to any defect that Cary Audio Design in its sole discretion determines is due to:

1. Improper maintenance or repair, including the installation of parts or accessories that do not conform to the quality and the specifications of the original parts.
2. Misuse, abuse, neglect or improper installation.
3. Accidental or incidental damage.

## WARRANTY DISCLAIMER

Except for the express warranties stated herein, Cary Audio Design disclaims all other warranties including, without limitation, all implied warranties of merchantability and fitness for a particular purpose. The foregoing constitutes Cary Audio Design's entire obligation with respect to this product, and the original purchaser and any user or owner shall have no other claim for incidental or consequential damages. Some states do not allow the exclusion or limitation of incidental or consequential damages, so the above limitation and exclusion may not apply to you. This warranty gives legal rights and you may also have other rights, which vary from state to state.

## EXCLUSIVE REMEDY

Notwithstanding the foregoing, the purchaser's exclusive remedy for any breach of warranty, express or implied, is limited to the repair or replacement of the defective unit or the refund of the purchase price, at the option of Cary Audio Design. Under no circumstances is Cary Audio Design liable for incidental or consequential damages. Any implied warranties imposed by law terminate one (1) year from the date of purchase.

## INTERNATIONAL PURCHASERS (Export markets)

Cary Audio Design warrants its merchandise to purchasers within the United States exclusively for use within the United States of America. It provides no other warranties, expressed or implied. If you are living outside the USA, please consult with your local dealer or distributor to determine the details of your local warranty.

**CARY AUDIO DESIGN**

1020 Goodworth Drive, Apex, NC 27539  
phone 919-355-0010  
fax 919-355-0013  
[www.caryaudio.com](http://www.caryaudio.com)

