

Audio Electronics

CD-1

OPERATING MANUAL

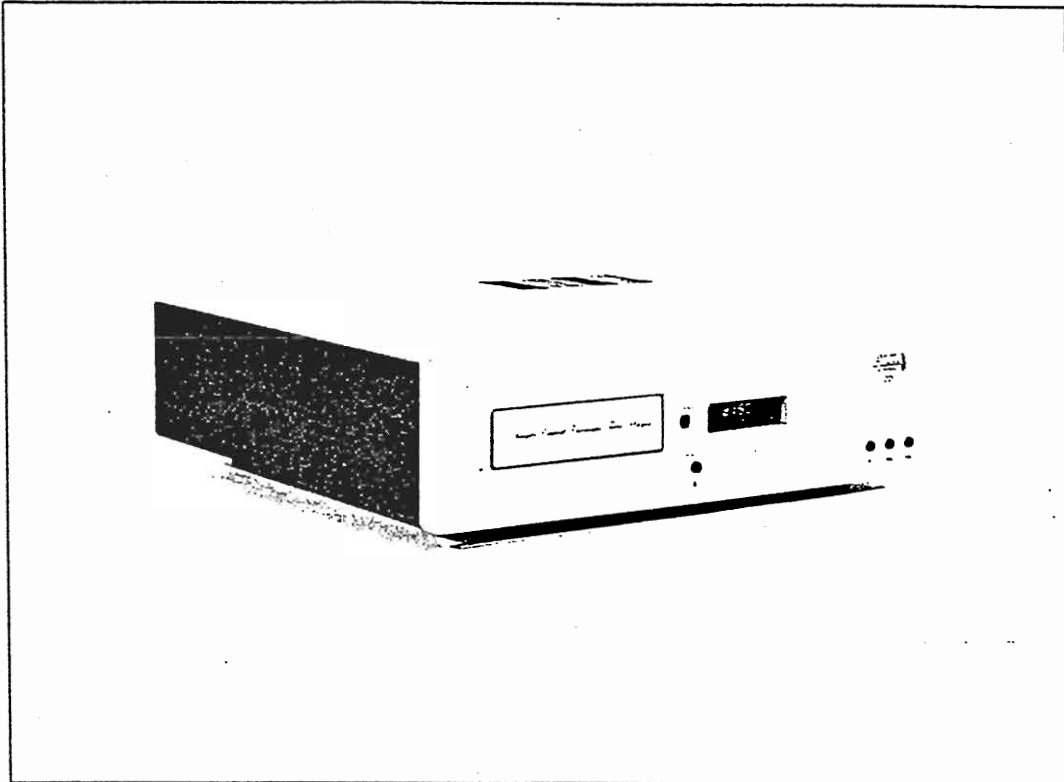

NOTE:

Before installing your new CD-1, Please read this manual carefully as it will inform you of the CD-1's specifications, proper installation procedures and operating procedures. Also included in this manual are guidelines on how to properly service and care for your new CD-1.

**CAUTION
RISK OF ELECTRIC SHOCK
DO NOT OPEN**

**CAUTION: TO REDUCE THE RISK OF ELECTRIC SHOCK
DO NOT REMOVE COVER(OR BACK)
NO USER-SERVICEABLE PARTS INSIDE *
REFER SERVICING TO QUALIFIED SERVICE PERSONNEL**

* EXCEPTION: The vacuum tubes inside are serviceable.

**CAUTION : THE UNIT MUST BE UNPLUGGED FROM
AC MAIN FOR AT LEAST ONE HOUR
BEFORE REMOVING COVER.**

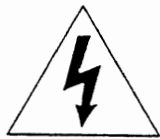

The lightning flash with arrowhead symbol, within an equilateral triangle, is intended to alert the user to the presence of uninsulated "dangerous voltage" within the product's enclosure that may be of sufficient magnitude to constitute a risk of electric shock to persons.



The exclamation point with an equilateral triangle is intended to alert the user to the presence of important operating and maintenance (servicing) instructions in the literature accompanying the appliance.

WARNING

**TO REDUCE THE RISK OF FIRE OR ELECTRIC SHOCK,
DO NOT EXPOSE THIS APPLIANCE TO RAIN OR MOISTURE.**

**CAUTION: TO PREVENT ELECTRIC SHOCK ,MATCH WIDE
BLADE OF PLUG TO WIDE SLOT, FULLY INSERT.**

LASER SAFETY

This unit employs a laser. Only a qualified service person should remove the cover or attempt to service this device, due to possible eye injury.

**CAUTION- USE OF CONTROLS OR ADJUSTMENTS
OR PERFORMANCE OF PROCEDURE
OTHER THAN THOSE SPECIFIED HEREIN
MAY RESULT IN HAZARDOUS RADIAT-
ION EXPOSURE.**

INSTALLATION

Remember the following important points when installing the player :

- * Do not expose the player to rain or moisture , as this may cause damage to the player.
- * All players produce some heat operation and this heat must be allowed to disperse freely. Do not close any ventilation openings and insure that there is adequate ventilation space behind ,beside and above the player.
- * Prevent extra heat from reaching the unit . Never put the player in the full glare of the sun or near a heat source.

PRECAUTIONS

The following precautions should be taken when operating the equipment.

GENERAL PRECAUTIONS

When installing the equipment ensure that:

- the ventilation holes are not covered.
- air is allowed to circulate freely around the equipment.
- it is placed on a vibration-free surface.
- it will not be exposed to excessive heat, cold moisture or dust.
- it will not be exposed to direct sunlight.
- it will not be exposed to electrostatic discharges.

In addition, never place heavy objects on the equipment.

If a foreign object or water does enter the equipment ,contact your nearest dealer or service center.

Do not pull out the plug by pulling on the main leads, grasp the plug.

It is advisable when leaving the house for an extended period, or during a thunderstorm, to disconnect the equipment from the main supply.

CONTROLS, CONNECTIONS AND INDICATORS:

A. ANALOG OUTPUT jacks

Connect to the CD or AUX input jacks of a preamplifier.

B. DIGITAL OUTPUT COAXIAL output jack

By connecting this jack to a digital audio component (D/A converter, digital sound processor, etc.) digital signals from compact discs can be transmitted directly from the player without first being converted to analog.

C. A/C POWER SOURCE CONNECTION

With the POWER switch set to the OFF position ,plug the mains lead into a mains outlet providing the right voltage.

1. POWER switch (located at rear of chassis)

Flip up for power on and down for power off.

2. OPEN/CLOSE button

Pressing the OPEN/Close button opens the disc tray . Place a compact disc on the tray with the label side facing up. Gently press the front of the disc tray to close.

3. REMOTE SENSOR

This window receives signals transmitted from the remote control unit. The indicator lights up when a signal is received.

4. DISPLAY

Shows the information such as the power ON/OFF state, track number, playing time and current operation mode.

a.Pause indicator

Lights up in the pause mode.

b.PLAY indicator

Lights up during CD playback.

c. TRACK indicator

Shows the track number of the track being played or programmed.

d. Elapsed playing time of the current track.

TOTAL: Indicates the total playing time of the disc. In program mode, this indicator shows the total playing time of the programmed tracks.

REMAIN: Indicates the remaining playing time of the current track.

TOTAL REMAIN: Indicates the remaining playing time of the entire disc. In the program mode, this indicator shows the remaining playing of the current program.

e. PROGRAM indicator

Lights up when the CD player is in program mode.

f. RANDOM indicator

Lights up when the RANDOM button is pressed.

g. EDIT indicator

Lights up when the player is in edit mode .

h. PEAK indicator

Lights up during peak search, and flashes during playback of the peak.

i. A / B indicators

A - Lights up when tracks to be recorded on side A of a tape are playing.

B - Lights up when tracks to be recorded on side B of a tape are playing.

j. Track number indicators

When a disc is placed on the tray and the tray is closed, the TOC* is read and the numbers of all the tracks on the disc are displayed " " lights up if there are more than 20 tracks on the disc. In program mode only the track numbers of the programmed tracks light up.

The track numbers go out in turn as each track finishes playing.

* TOC is the disc's "Table Of Contents" and contains non-audio data such as the track numbers and playing times of all the tracks on the disc.

k. REPEAT indicators

Repeat 1 : Lights up during 1-track repeat mode, which repeatedly plays a single track repeatedly.

REPEAT : Lights up during all-track repeat mode, which plays all the tracks on the disc repeatedly. Also lights up during program repeat mode, which plays all the programmed tracks repeatedly.

5. PLAY (>) button

Press to start playback.

When pressed during playback, the CD player returns to the beginning of the current track and plays the track again. The indicator lights up during playback.

6. |<<, >>| (Track Previous/Next) buttons

When the << button is pressed during playback, play re-starts at the beginning of the previous or a preceding track.

When the >> button is pressed, play re-starts at the beginning of the next or a subsequent track. The same number of tracks as the number of times the button is pressed can be skipped.

The selected track number is shown on the display.

These buttons can also be used to select a desired track from which to start playback.

These buttons are also used in program mode to select tracks for programming.

NORMAL PLAYBACK

1. Flip the **POWER** switch up to turn on the power.

2. press the **OPEN/CLOSE** button.

When the disc tray opens ,place a disc on the tray with the label side up.

3. Gently press the front of the disc tray or press the **OPEN/CLOSE** button to close tray.

4. Press the **PLAY** button.

When the button is pressed, the **PLAY** indicator lights up.

While the disc is playing, the display shows the track number and elapsed playing time of the track

currently playing, along with the numbers of the tracks still to be played or playing.

When the last track has finished paying, the CD player stops automatically.

To start playback again from the first track:

Press the **PLAY** button .

To stop playback:

Press the **STOP** button.

To remove disc:

Open the disc tray by pressing the **OPEN/CLOSE** button, remove the disc, then close the tray by lightly pressing its front edge. Always keep the disc tray closed even when the CD player is not being used.

To pause playback:

Press the **PAUSE** button.

The **PAUSE** indicator lights up and playback pauses at the position where the button was pressed. To resume playback from the pause position, press the **PAUSE** button again.

To switch the time display:

Press the **TIME** button.

Each time the **TIME** button is pressed, the time display changes in the following order:
elapsed playing time of current track > REMAIN > TOTAL > REMAIN > elapsed playing time of current track.

Scanning (locating a desired passage)

To find a passage located after the current position:

Press the **>>** button.

To find a passage located before the current position:

Press the **<<** button.

normal playback resumes from the position where the button is released.

* When one of these buttons is pressed, scanning is first carried out at slow speed and sound is heard for about 3 seconds. After that, scanning is carried out at high speed.

SEARCHING/SKIPPING

Direct search(specifying a desired track number)

Specify the track number using numeric buttons 0 to 9.

For track number 3, press 3.

For track number 12, press 1, then within 1.5 seconds, press 2.

in the first of two digits pressed is not one of the digits on the CD, it is interpreted as 1 digit and the search will start after about 0.5 second.

if you make a mistake when pressing the numeric buttons:

Press the right buttons to enter the correct track number.

* if you specify a track number which does not exist on the disc "Error" will appear on the display. Enter the correct number.

Skip(skipping to a desired track located after the track currently playing)

Press the >>| button the necessary number of times to skip to the desired track.

Skip(skipping to a desired track located before the track located before the track currently playing)

Press the |<< button the necessary number of times to skip to the desired track.

* Pressing the |<< button in the middle of the first track in the disc skips to the last track, and pressing the >>| button in the middle of the last track skips to the first track.

Listening to the first part of each track (AMS)

1. Press the AMS button.

The first part(10 seconds) of each track on the disc will be played in the order in which they are recorded.

2. When you find a track you want to listen to, press the AMS button again.

* If the |<< or >>| button is pressed during AMS search, the CD player increases or decreases the played track number the same number of times as the button was pressed, but AMS search is not canceled.

* if the AMS button is pressed during playback or in stop mode, AMS search is will begin automatically and AMS search will begin.

REPEAT PLAY

1-TRACK REPEAT

(repeated playback of one track only)

While the track you want to repeat is playing, press the REPEAT button twice.

The "REPEAT" and "1" indicators light up and the current track will be played repeatedly.

To cancel 1-track repeat play:

Press the REPEAT button once.

All-Track repeat(repeated playback of all tracks on the disc)

During playback, press the REPEAT button once.

The "REPEAT" indicator lights up and all the tracks on the disc are played repeatedly.

Even if the REPEAT button is pressed in stop mode, playback will start and repeat playback will be carried out.

To resume normal playback:

Press the REPEAT button twice. The "Repeat" indicator goes out, repeat mode is canceled and normal playback resumes.

A-B repeat

(repeated playback of a specified passage)

1. During playback, press the remote control unit's A-B button at the starting point of the passage you want to repeat.

2. Press the A-B button again at the end of the passage you want to repeat.

The designated passage A-B will be played repeatedly.

To cancel A-B repeat play:

Press the A-B button. The indicator goes out, A-B repeat is canceled and normal playback resumes.

RANDOM PLAY

In this mode, the CD player automatically selects and plays tracks in random order. All tracks are played once.

Press the RANDOM button.

*During random playback, tracks are separated by an interval of about 4 seconds.

*The RANDOM button can be pressed either during playback or in stop mode.

If the RANDOM button is pressed while the disc tray is open with a disc on the tray, the disc tray automatically closes and random playback begins.

*To stop random playback and resume normal playback:

Press the RANDOM button again.

*If the >> button is pressed during random playback:

Each time one of these buttons is pressed, the CD player selects a track at random and starts playing that track.

*If the << or >> button is pressed during random playback:

Searching is carried out with the current track. The search operation will not cross over into the previous or next track.

*To repeatedly play tracks at random:

Press the REPEAT button once. All tracks are repeatedly played in random order, with the order being changed each time the disc is played.

Delete random playback

With this function you can play tracks in a random order while skipping unwanted tracks.

1. Program tracks according to the "delete programming" procedure in section "PROGRAM PLAY"

2. When programming is completed, press the RANDOM button. All tracks other than the deleted tracks are played in random order.

PROGRAM PLAY

To play the desired tracks in a certain order (programming)

(Example: To program track number 6 first, then track number 14 on a 14-track disc)

1. Press the **PROGRAM** button in stop mode. The PROGRAM indicator flashes.
2. Specify the first track to be programmed using the numeric buttons or the **>>|** or the **|<<** button.
3. Then program another track by repeating the procedure in step 2 above.
4. After having programmed all the desired tracks, press the **PROGRAM** button or **STOP** button. The PROGRAM indicator status changes from flashing to continuously lit, indicating that the program is complete.

5. Press the **PLAY** button. The programmed tracks will be played in the programmed order.

Listening only to the desired tracks by omitting unwanted tracks(delete programming)

(Example: To program the tracks on a 14-track disc with the exception of track numbers 3 and 7.

1. Press the **PROGRAM** button on stop mode and, when the PROGRAM indicator starts to flash press the **CANCEL** button. The total number of tracks and total playing time of the disc will be displayed.

2. Select the unwanted tracks using the numeric buttons or the **>>|** or **|<<** button.

3. After having selected and deleted all of the unwanted tracks, press the **PROGRAM** button or the **STOP** button.

The PROGRAM indicator status changes from flashing to continuously lit, indicating that the program is complete.

4. Press the **PLAY** button. The tracks except for the deleted tracks will be played on the order of the track numbers.

*When the tracks have been programmed by programming or delete programming, it is also possible to begin program playback immediately by pressing the **PLAY** button or **RANDOM** button

* Take note of the following points when programming tracks by programming or delete programming.

*When selecting track numbers 1 to 9 using numeric buttons from a disc containing 10 or more tracks (when selecting track number 3 after track number 2, for example) press 3 more than 1.5 seconds after pressing 2.

*When using numeric buttons to select track number 10 or higher on a disc containing 10 or more tracks (for example when selecting track number 13) Press 3 within 1.5 seconds of pressing 1.

*When using numeric buttons to select track number on a disk containing no more than 9 tracks (when selecting track number 5 after track number 4, for example) Press 5 more than about 0.5 seconds after pressing 4.

*When programming track numbers using the **>>|** or **|<<** buttons, press buttons with intervals of less than 1 second.

To check the programmed contents.

Press the RECALL button during programming or program playback. If it is pressed during "programming" the programmed track numbers will be displayed sequentially in the order they've been programmed . If it is pressed during "delete programming", the deleted track numbers will be displayed.

To erase some of the programmed tracks:

1.Press the RECALL button to display the programmed track numbers sequentially in the order in which they have been programmed.

2.When the track number to be erased from the program is displayed, press the CANCEL button immediately.

The track number indicator of the track erased from the program goes out.

To re-incorporate in the program a track which has been deleted in "delete programming":

1.Press the RECALL button during delete programming to display the deleted track numbers sequentially in the order in which they were deleted.

2.When the track number to be added to the program is displayed, press the CANCEL button immediately.

The track number indicator of the track added to the program lights up.

To erase the entire program:

During program playback, press the STOP button twice. IN stop mode ,press the STOP button once.

*The program is also erased by pressing the OPEN/CLOSE button to open the disc tray.

To add tracks to the program:

In stop mode with the program stored in the memory (that is ,with the PROGRAM indicator lit up) press the PROGRAM button. the PROGRAM indicator starts flashing and more tracks can be added to the program.

Q & A

***how many tracks is it possible to program?**

Up to 30 tracks can be included in the program. With delete programming ,up to 30 tracks can be omitted from the program.

***Is it possible to change from programming to delete programming or visa versa?**

No.

***How do you play programmed tracks repeatedly?**

Press the REPEAT button once. The REPEAT indicator lights up and the program playback will be repeated.

***How do you play programmed tracks in a random order?**

Press the RANDOM button during program playback or in stop mode.

EDITING

When recording from a compact disc to a tape, use this function to match the tape length to the playing time of the tracks to be recorded and to create 4-second intervals between the tracks.

Auto peak level search

If the cassette deck recording level is adjusted in relation to the peak level on the disc, it is possible to avoid distortion and noise in recording. This facility allows the peak over the entire disc or in the programmed to be detected tracks before proceeding to editing.

Simple edit

This operation fits tracks into a specified tape length while keeping the tracks in their original order.

1. Press the **EDIT** button in stop mode to light up the EDIT indicator. The tape recording time display(90) appears.

2. Specify the recording time of the tape used using the numeric buttons (0-9) or the **|<<** or **>>|** buttons.

*When numeric buttons are used to specify a C-46 tape, for example, press 4 then 6..

Use of **|<<** and **>>|** buttons.

Each press of the **>>|** button allows you to change the recording time in the order 90,46,60,90.

Each press of the **|<<** button allows you to change the recording time in the order 90,60,46,90

Each press of the **>>** button allows you to increase the recording time by 1 minute.

Each press of the **<<** button allows you to decrease the recording time by 1 minute.

3. Press the **PLAY** button. The **PEAK** indicator lights up and auto peak level search operation starts from track number 1.

4. After the auto peak level search of the last track has finished, the passage of about 4 seconds centered around the peak position will be played 4 times. Adjust the recording level of the cassette deck during this period. For the adjustment procedure, refer to the instruction manual supplied with your cassette deck.

5. After the peak passage has been played 4 times, the CD player enters the pause mode.

6. Press the **PAUSE** button to start edit play for tape side A.

7. After edit play for tape side A has been completed, the CD player automatically enters pause mode.

8. To start edit play for side B, press the **PAUSE** button.

NOTE:

As a CD may contain several peaks, a different peak may be found every time the auto peak level search operation is performed.

During simple edit play, operations other than the STOP, OPEN/CLOSE and TIME operations are blocked. This is intended to prevent mistakes in recording due to erroneous operation.

Program edit

This procedure allows you to record tracks in any desired order while fitting the tracks into a specified tape length.

1. Program tracks according to the programming procedure in section "PROGRAM PLAY"
2. The rest of the program edit procedure is the same as step 1 to 8 in the simple edit procedure.

NOTE:

During program edit play, operations other than the STOP, OPEN/CLOSE, RECALL and TIME operations are blocked. This is intended to prevent mistakes in recording due to erroneous operation.

Delete program edit

When recording from a disk to a tape, this procedure allows you to omit the tracks you do not want to record, while fitting the tracks into a specified tape length.

1. Program tracks according to the "delete programming" procedure in the "PROGRAM PLAY" section.
2. The rest of the delete program edit procedure is the same as step 1 to 8 in the simple edit procedure.

NOTE:

During delete program edit play, operations other than the STOP, OPEN/CLOSE, RECALL and TIME operations are blocked. This is intended to prevent mistakes in recording due to erroneous operation.

***If you want to skip the auto peak level search:**

In step 3 of the simple edit procedure, press the **PLAY** button twice in succession within less than 0.5 second. The PAUSE indicator lights up and the CD player enters the pause mode. When the **PAUSE** button is pressed later on, the edit play for tape side A will start immediately, without the auto peak level search operation.

REMOTE CONTROL UNIT CD-1

when the power to the CD player is ON and a disc is loaded on the disc tray, the remote control unit can be used to operate the player's various functions. However the power to the CD player must be switched ON/OFF using the POWER switch on the main unit. The AMS, REPEAT, A-B REPEAT, RANDOM and VOLUME functions are carried out using the buttons on the remote control unit.

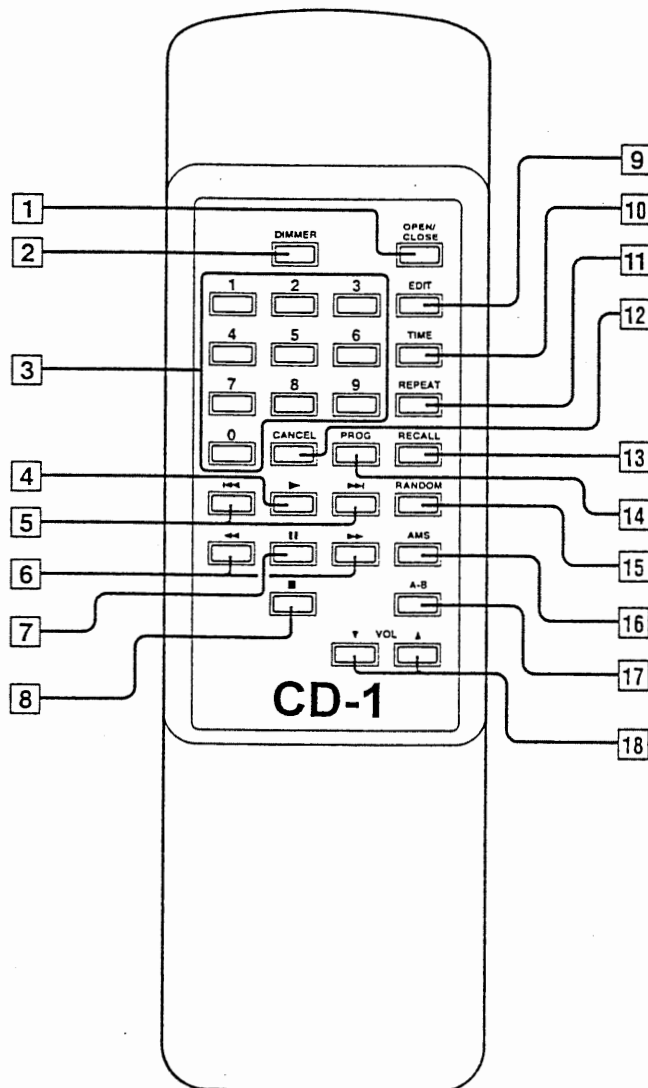

1.OPEN/CLOSE button

Press to open and close

2.DIMMER button

Press to adjust the display illumination brightness. The illumination at its the brightest when the power is switched ON. Each time the button is pressed, the brightness dims until the forth place, after which the illumination returns to the original brightness.

3.Numeric(0-9)buttons

When used during playback, these buttons allow you to specify the number of another track you want to play.

When used during stop mode, these buttons allow you to specify the number of another track from which to start playback.

These buttons are also used to select tracks for programming.

4. > (PLAY) Button

Press to start playback.

When pressed during playback, the CD player returns to the beginning of the current track and plays the track again.

5. |<< , >>| (Track Previous/Next) button

When the << button is pressed during playback, play re-starts at the beginning of the previous or a preceding track. When the >> button is pressed, play re-starts at the beginning of the next or a subsequent track. The same number of tracks as the number of times the button is pressed can be skipped.

The selected track number is shown on the display.

These buttons can also be used to select a desired track from which to start playback.

These buttons are also used in program mode to select tracks for programming.

6. << , >>(Search Reverse,Forward) buttons

<< : When pressed during playback, this button fast-reverses the play position.

>> : When pressed during playback, this button fast-forwards the play position.

7. || (Pause) button

Press to interrupt playback temporarily. When pressed again, the indicator goes out and playback resumes.

8. ■(Stop) button

Press to stop playback. This button is also used for deleting a program.

9. EDIT button

Press to put the CD player into edit mode.

10. TIME button

Switches the time shown on the display to the remaining time of the current track(REMAIN) or the remaining time of the entire disc(TOTAL REMAIN)

11.REPEAT button

Press to select 1-track repeat, all-track repeat or program repeat playback mode.

12.CANCEL button

Used to delete specified track numbers from a program.
Also used when creating programs by deleting any tracks which you do not want to listen to (delete programming)

13.RECALL button

Pressing this button displays the programmed track numbers and program numbers (steps) in sequence.

14.PROG button

Press to switch between the play mode and program mode.

15.RANDOM button

When this button is pressed, the player enters random play mode(tracks on the disc are selected and played in a random order). When pressed again,random play is canceled.

16.AMS(Automatic Music Scan)button

When this button is pressed, the player automatically plays the first part of each track on the disc for 10 seconds.

17.A-B button

Used to set the starting and stopping points of a passage for repeated playback.

18.VOL(↑)/VOL(↓)buttons

press to vary the ANALOG OUTPUT volume between 0 and-30 dB. The level when the power is turned on is 0 dB (maximum volume.)

TROUBLESHOOTING

If you think a malfunction has occurred, first check the points listed below. The problem is likely to have been caused by a simple operational error or a connection problem. If the problem cannot be corrected even after carrying out the following checks, consult your dealer or the Audio Electronics Service Department.

*** The disc fails to rotate.**

1. Is the main lead plugged in properly?
2. Is the POWER switch ON?
3. Is the disc placed in the correct position on the disc tray?
4. Is the disc placed properly with the label side facing up?
5. Is the disc dirty?
6. Is the disc scratched?
7. Is the disc warped?

*** The disc is rotating but no sound is heard.**

1. Are the amplifier and speakers connected properly?
2. Is the amplifier switch ON?
3. Is the amplifier's volume control set at the minimum level?
4. Is the amplifier's selector switch set to the correct input ("CD" or "AUX" whichever corresponds to the input jacks the CD player is connected to)?

*** The disc stops in mid-operation.**

1. Is the disc dirty?
2. Is the disc scratched?
3. Is the disc warped?

*** The sound drops out or noise is heard.**

1. Is the disc dirty?
2. Is the disc scratched?
3. Is the disc warped?

*** Remote control operation is not possible.**

1. Is the CD-1 remote control unit's transmitter pointed correctly at the remote sensor on the front of the CD player?
Or is there an obstruction between the transmitter and the remote sensor?
2. Are the batteries in the remote control unit exhausted?
3. Is there another strong light (from a window, etc.) striking the CD player's remote sensor?

UNITED STATES LIMITED WARRANTY

Audio Electronics warrants to the original United States purchaser for use in the United States, that this product shall be free from defects in material (except tubes and AF output transistors) or workmanship for:

Amplifiers and Preamplifiers, Three (3) years from the date of the original purchase.

Speakers, Five (5) years from the date of the original purchase.

Digital Products, One (1) year from the date of original purchase.

During the warranty period, Audio Electronics or an authorized Audio Electronics service facility will provide free of charge both parts (except tubes and AF output transistors) and labor necessary to correct defects in material or workmanship.

To obtain such warranty service, the original purchaser must:

- (1) Complete and send in the warranty Registration Card.
- (2) Notify Audio Electronics as soon as possible after the discovery of a possible defect:
 - (a) The model number and serial number.
 - (b) The identity of the seller and the approximate date of purchase.
 - (c) A detailed description of the problem, including details on the electrical connection in the associated equipment and the list of such equipment.
- (3) Deliver the product to Audio Electronics or the nearest authorized service facility, or ship the same in its original container or equivalent, fully insured and the shipping charges prepaid.

Correct maintenance, repair and use are important to obtain optimum performance from this product. Therefore, carefully read the Operating Manual. This warranty does not apply to any defect that Audio Electronics in its sole discretion determines is due to:

- (1) Improper maintenance or repair, including the installation of parts or accessories that do not conform to the quality and the specifications of the original parts.
- (2) Misuse, abuse, neglect or improper installation.
- (3) Accidental or incidental damage.

WARRANTY DISCLAIMER

Except for the express warranties stated herein, Audio Electronics disclaims all other warranties including, without limitation, all implied warranties of merchantability and fitness for a particular purpose.

EXCLUSIVE REMEDY

Notwithstanding the foregoing, the purchaser's exclusive remedy for any breach of warranty, express or implied, is limited to the repair or replacement of the defective unit or the refund of the purchase price, at the option of Audio Electronics. Under no circumstances is Audio Electronics liable for incidental or consequential damages. Any implied warranties imposed by law terminate one (1) year from the date of purchase.

FOREIGN PURCHASERS

Audio Electronics warrants its merchandise to purchasers in the United States for use in the United States. It provides no other warranties. The foregoing constitutes Audio Electronics entire obligation with respect to this product, and the original purchaser and any user or owner shall have no other claim for incidental or consequential damages, so the above limitation and exclusion may not apply to you.

This warranty gives legal rights and you may also have other rights which vary from state to state.