

CAD-300SEI

OPERATING MANUAL



NOTE:

Before installing your new integrated amplifier, please read this manual carefully as it will inform you of the unit's specifications, proper installation and operation procedures. Also included in this manual are guidelines on how to properly service and care for your new CAD-300SEI.

CAD-300SEI
Single-Ended Stereo Integrated Amplifier

INTRODUCTION

Congratulations! You have purchased one of the most exotic vacuum tube audio amplifiers available. Within its power range, the CAD-300-SEI integrated amplifier offers the most realistic sound reproduction one could desire for a "high-end" home audio system. Careful design, parts selection and proper circuit topologies contribute to incredible reliability and enjoyment.

For the technically minded, a review of the circuit is in order. Your new CAD-300SEI operates in a Class A single-ended mode utilizing fixed negative grid voltage on the 300B triode output tube. The input preamplifier section utilizes a 6SN7 dual triode tube. One triode section of this dual tube is used for the left channel and the other triode section is used for the right channel. This circuit is a Class A voltage gain circuit. This is the same basic first stage input circuit utilized in the Cary Audio model SLP-90 preamplifier. The next gain stage in the CAD-300SEI utilizes a 6SN7 dual triode wired in a series constant-current plate-loaded configuration. This stage is duplicated for each channel. The series constant-current configuration then drives the 300B triode output stage in single-ended. The output transformers in the CAD-300SEI are the most important components in the amplifier and have been specifically designed by Cary Audio for use in the CAD-300SEI. The output transformer is an air-gap design with a commercial continuous rating of 200% duty cycle. The CAD-300SEI output transformer is an E/I laminate, silicon impregnated, grain oriented steel design. The windings are wax vacuum impregnated and the entire transformer is potted in high temperature wax. Utilizing the linear directly heated filament-cathode 300B triode output tube, there is no global feedback used in the CAD-300SEI. The power supply is a full wave center tap configuration running high voltage, high current fast switching diodes rectifiers. The rectified 430 VDC is fed to a pi-L filter network. The filter capacitors consist of two (2) 1200 MFD and one (1) 100 MFD computer grade electrolytics for a total of over 230 Joules of energy storage. Each electrolytic capacitor is by-passed with a low impedance .22 polystyrene capacitor. The power transformer is also a 200% duty cycle rating on the CAD-300SEI. To avoid AC hum, both the 6SN7 and 300B tubes have DC voltage on the filaments. This will prevent AC ripple voltage from capacitively being coupled to the elements in the tubes.

ADDITIONAL DESIGN THOUGHTS

A great deal of attention during design of your new CAD-300SEI was concentrated on the "overload recovery" ability of the amplifier. The ability of an amplifier to instantly recover from clipping is much more important than is commonly believed. In the power war of

amplifier manufacturers the mentality is focused on high and then even higher power output to solve the clipping problem. When in reality the most critical aspect is how fast a recovery an amplifier can achieve after overload. With the incredible dynamic range of live and in turn recorded music even 2000 watts of power is not enough power. Most of the music being listened to in an average listening room is only requiring about 3 watts of power. It is on the transients of loud low frequency program material that tremendous signal voltages will appear at the input of the amplifier. It is in this situation that the overload recovery ability of an amplifier is of critical concern. The single-ended CAD-300SEI extols its merits in the ability to handle transients and instantaneously recover from brief or even extended overloads. The CAD-300SEI will overload symmetrically at any frequency in the audio bandpass. The CAD-300SEI will also yield faithful reproduction of extremely low frequencies at full output levels. Power transformer, power supply regulation and output transformer design and careful shaping of the overall frequency response curve all play a very important part in the ability of the CAD-300SEI to recover quickly when overloaded. If one were to monitor the high voltage rail voltage (385 VDC at the anode of 300B tube) of a CAD-300SEI during soft and also loud music passages it will be found there is no more than a volt or so change from soft to loud passages.

Another technical feature of your new CAD-300SEI is amplifier stability. The CAD-300SEI may be operated with no load (without speaker) without damage to the amplifier, output transformers or tubes.

The most exciting feature of your new CAD-300SEI, aside from how compact and gorgeous it looks, is the delightful, sensual beauty of the music it recreates. The first thing that will strike you about your new CAD-300SEI amplifier is the incredible transparency and resolution of detail in the music. The CAD-300SEI's sensual nature is best revealed in the sense of life it displays in female vocalists.

Your new CAD-300SEI integrated stereo amplifier presents music with such presence and directness, you'll be drawn into the music hour after musically satisfying hour. This is the result of single-ended circuit techniques which eliminate any crossover notch at low levels, and also contributes to the freedom from listening fatigue. The CAD-300SEI will draw you in even further as you realize how lucid and utterly uncolored neutrality reveals delicate nuances in the sound stage.

Enjoy the music, and, of course, please read this manual for a complete understanding of trouble-free operation.

SPECIFICATIONS

Operating the CAD-300SEI stereo amplifier is a simple procedure since each unit is designed for long term stability in virtually any home operating situation. Therefore, if the unit is operated outside the parameters outlined in this owner's manual, damage may result. Please read this manual carefully before putting your new Cary Audio Design CAD-300SEI in operation.

The following definitions are applicable to this manual. These definitions must be followed explicitly.

WARNING

HAZARD PRESENTS PERSONAL INJURY OR DEATH

Caution

EQUIPMENT DAMAGE MAY OCCUR BUT NOT PERSONAL INJURY

Note

Proper performance of the amplifier cannot be ensured if disregarded

1.2 Specifications

The following section describes the CAD-300SEI's basic specifications. Specifications are subject to change without notice or obligation.

DIMENSIONS: 8"H x 14"W x 14"D

WEIGHT: 42 Lbs.

CIRCUIT TYPE: Single-Ended, Class A

INPUTS: CD, AUX1, AUX2

POWER OUTPUT: 4/8 ohms = 11 watts/CH

S/N: 90dB below rated power output

FREQUENCY RESPONSE (11 WATT): 23 - 20,000 Hz (+0 - 0.75dB)

HEADPHONE OUTPUT: 4-50 ohm compatible 1/4" 3 circuit jack

RESISTOR: 1% metal film

OUTPUT TRANSFORMER: 200% duty cycle
Air gapped, wound with OFC
copper wire, wax impregnated

WIRE: Silver double "E" teflon

COUPLING CAPS: Oil filled

POWER SUPPLY CAPACITORS: 2 - 1200MFD @ 450VDC,
TOTAL = 2400MFD - 230 Joules

WIRING: Point-to-point

LINE INPUT: 3 switchable selections

SPEAKER POSTS: 5-way Copper

TUBE SOCKETS: Ceramic silver pins

ADDITIONAL FEATURES: Soft shoe feet
Detachable power cord

TUBE COMPLIMENT: 2 - 300B triode output tubes in
Class A single-ended
3 - 6SN7 input driver tubes

WARM-UP TIME: 3 minutes

BREAK-IN PERIOD: 100 hours of music playing time

FINISH: Stainless steel chrome chassis with
high gloss anodized black front panel.
(24 Karat Gold front panel & knobs optional)

1.3 Front Panel Features

AC-ON SWITCH: Turns AC power on in the "up" position

INPUT SELECTOR: Selection of line inputs (CD, AUX1, and AUX2)

LISTENING LEVEL: Dual precision potentiometer controlling volume of
both channels

BALANCE: Dual precision potentiometer controlling the balance between
left and right channels

HEADPHONE: 3 conductor stereo headphone jack for low impedance
headphones

OUTPUT SELECTOR: Switches amplifier output from speakers to head-
phones. When blue LED lights, the headphone jack is
activated. (Located on top right of chassis)

1.4 Rear Apron Features

INPUTS: Signal input connection via shielded interconnect cable.

SPEAKER OUTPUT: Copper 5-way binding posts provide output to the
speaker system.

POWER CORD: 3 conductor shielded power cord to A.C. power mains.

CAUTION
USE OF ANY OTHER PROTECTION FUSE CAN DAMAGE UNIT

FUSE: AC power fuse. Never replace with any other fuse than 2 AMP
SLOW BLOW! 250 VOLT!

CAUTION
NEVER REMOVE/INSERT AC LINE CORD WHEN THE UNIT IS ON

INSTALLATION

This section describes the unpacking and installation procedures for the CAD-300SEI stereo amplifier.

WARNING
MAKE NO ATTEMPT TO PUT THE CAD-300SEI AMPLIFIER IN SERVICE
WITHOUT THE BOTTOM PLATE ATTACHED - CONTACT WITH VOLTAGE
IN THE CAD-300SEI CAN BE FATAL!!

2.2 Unpacking

Carefully remove your new amplifier from its packing carton, and examine it closely for signs of shipping damage. It is recommended to save all original packing cartons to protect your amplifier from damage should you wish to store it or ship it for after-sales service.

All shipping containers have been specifically designed to protect their contents and special care has been taken to prevent damage under normal shipping conditions. Mishandling should be evident upon inspection of the shipping container. If damage is found after visual inspection, take care not to destroy the evidence. If necessary, document the damage with photographs and contact the transport carrier immediately.

2.3 Warranty Card

Fill out the enclosed warranty registration card and return to Cary Audio Design, Inc. within 10 days of original purchase. Keep your original sales slip with the packing cartons should you ever need it for reference. Failure to register warranty will limit the warranty to one year.

2.4 Amplifier Placement

In general, the location of your new CAD-300SEI amplifier is not critical. The best placement in your system is near the speaker system with short lengths of speaker cables. Certain precautions must be taken to ensure optimum performance. Avoid extremely hot locations such as near radiators or other heating units. Keep the top of the CAD-300SEI clear of books, paper or other equipment to protect against overheating.

2.5 Power Requirements

The CAD-300SEI is designed to operate from house current mains. The design voltage is 117VAC at 50/60Hz. (Foreign units 220 VAC at 50/60Hz)

2.6 Cables

The speaker cables from the output posts of the CAD-300SEI to the speaker system can be any convenient length your set-up requires. Select speaker cables of sufficient size to preserve the outstanding performance capabilities of your amplifier. Heavy gauge #16 wire is suitable for distances up to 10 feet; #12 for 25 feet. Most audio dealers will have proper speaker cable in stock for this purpose.

OPERATION

Signal input connections are made via the input jack on the rear of the CAD-300SEI located next to the output binding posts. The interconnect cables from the output of the preamplifier can be any convenient length your set-up requires. The choice of a high quality interconnect cable is important. Once again, your audio dealer will have the proper cables in stock for this purpose.

3.1 Operation

Your new amplifier is ready for operation after the speaker, interconnect cables and all the tubes have been installed. Refer to the tube outline drawing inserted in this manual for tube placement.

3.2 AC On Power Switch

Simply push the AC rocker switch up to the ON position. Observe that the blue LED lights and all tubes are lit (filaments).

3.3 Break In Period

The tubes, capacitors and output transformers take approximately 100 hours of music playing to fully settle in for peak performance. The CAD-300SEI may seem sterile or thin sounding right out of the box. After the first couple of hours you will notice increased depth and tighter bass. This break in period defies all engineering theory, but is true with most audio amplifiers.

WARNING
MAKE SURE AMPLIFIER IS UNPLUGGED FROM AC MAINS
FOR ANY SERVICE OR CLEANING!

SERVICE AND CARE

4.1 CAD-300SEI Care and Cleaning

The chassis of the CAD-300SEI may be cleaned with a soft rag and Windex (or a similar window cleaner). The frequency of cleaning will be governed by how many hours the amplifier is operated and by operating environmental cleanliness.

4.2 Tube Replacement

If it becomes necessary to replace the tubes in the CAD-300SEI amplifier, a matched set of tubes of the same brand should be used. A new tube kit is available from Cary Audio Design, Inc. You should get year's from the output tubes with everyday usage and many, many years of use from the 6SN7 input tubes.

4.3 Factory Service

Careful consideration has been given to the design of your amplifier to keep maintenance problems to a minimum. However, it is possible that some problems may arise which cannot be cured by tube substitution. At this point we suggest that you contact our Customer Service Department, phone number 1-919-481-4494, to describe your problem in detail. Do not return the CAD-300SEI to the factory without a return authorization number from the Customer Service Department. Cary Audio Design, Inc. will assume no responsibility if the transportation company refuses to pay a damage claim due to your improper packing or lack of insurance should the unit be lost in shipment.

WARNINGS
MAKE NO ATTEMPT TO PUT THE CAD-300SEI IN SERVICE OUTSIDE OF THE
CABINET. CONTACT WITH HIGH VOLTAGES FOUND IN THE UNIT CAN BE
FATAL!!!

COMPLETELY REMOVE AC POWER PLUG FROM THE WALL AND ALLOW 30 MINUTES FOR THE HIGH VOLTAGE CAPACITORS TO DISCHARGE THROUGH BLEEDER RESISTORS BEFORE ATTEMPTING TO CHANGE TUBES OR CLEAN THE INSIDE OF THE AMPLIFIER.

CAUTIONS

NEVER REMOVE/INSERT AC PLUG WHEN THE UNIT IS ON OR THE AC POWER SWITCH IS IN THE "ON" POSITION.

OBSTRUCTION OF THE TOP PORTION OF THE CAD-300SEI WILL RESULT IN TUBES OVERHEATING.

OBSERVE DIRECTIONS IN THIS MANUAL

PROPRIETARY RIGHTS: Cary Audio Design, Inc. has proprietary rights in the design and components of its units. While the purchaser is entitled to use the unit for its intended purpose, use of the unit for copying, imitation, or reverse engineering is a violation of these proprietary rights and is forbidden.

300sei Bias Adjustment

Adjust bias pot until meter read 160mA

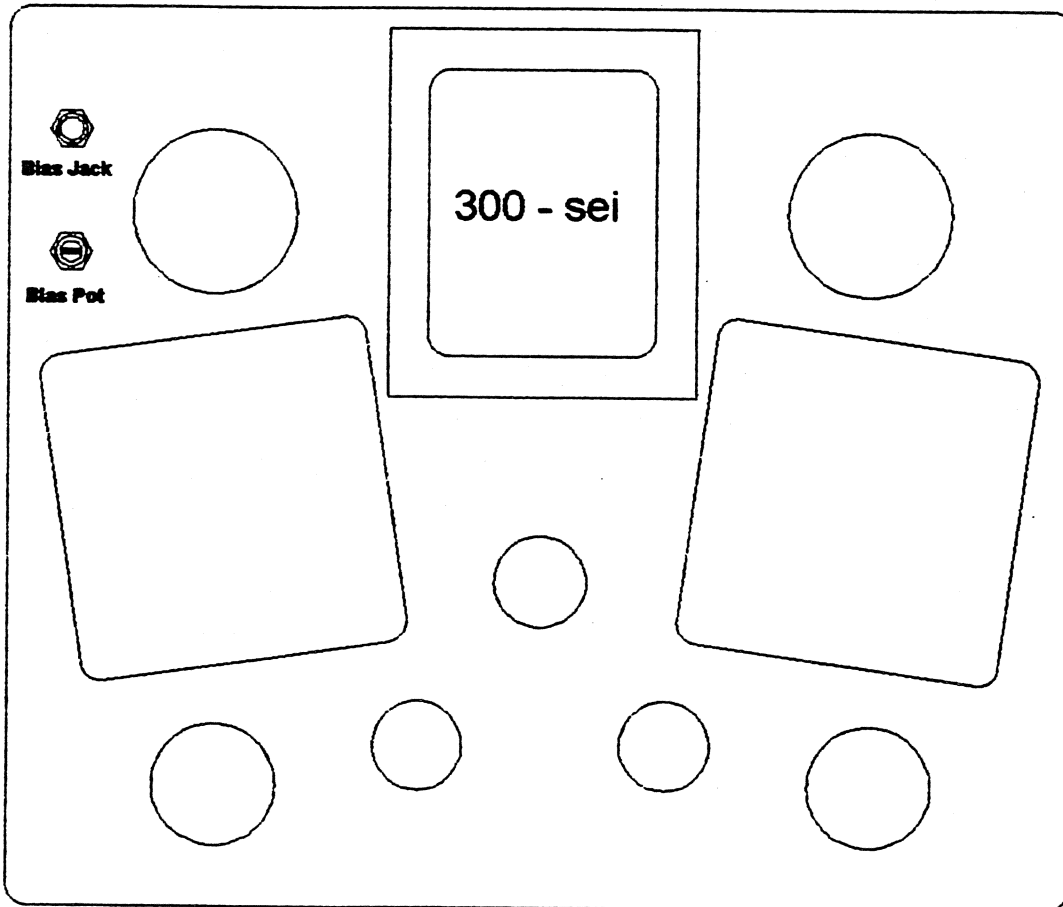
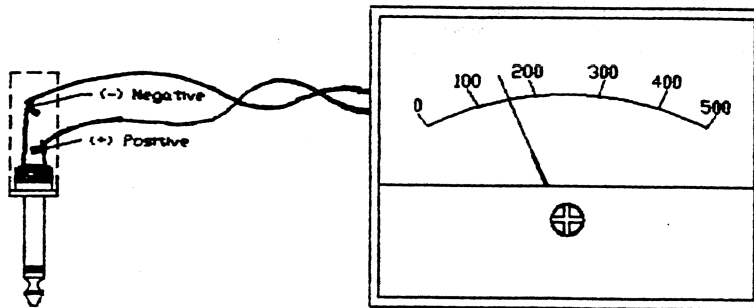

Insert meter plug into bias jack.
Adjust for 160mA reading on VOM or DC current meter.
Readjust to setting after amp has warmed up for 10 minutes.
Remove plug and enjoy the music!

REAR

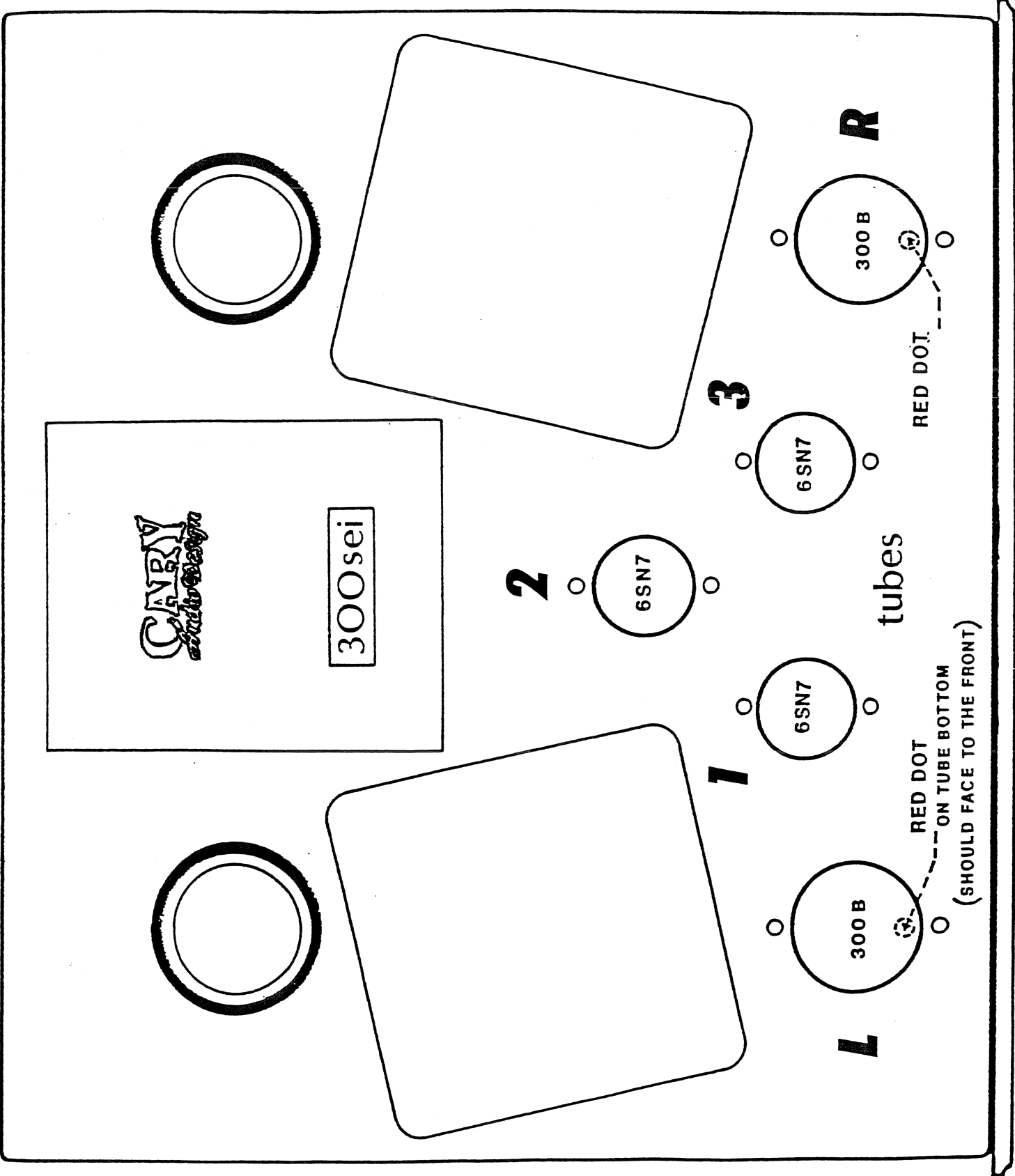

FRONT

300B
TUBE

THIS SIDE OF TUBE
CHIMNEY SHOULD FACE
TO THE FRONT

PRINT SHOULD FACE
TO THE FRONT

300 B

LARGE PINS TO
LARGE HOLES IN
SOCKET FRONT

RED DOT INDICATES
LARGE PINS ON TUBE

IMPORTANT! IMPORTANT!

THE TWO LARGE PINS ON THE BASE
OF THE 300B TUBES MUST FACE
THE FRONT OF THE CAD-300 AMPLIFIER!!

RED DOT INDICATES
LARGE HOLES LOCATION
AND SOCKET-FRONT SIDE

AMPLIFIER FRONT

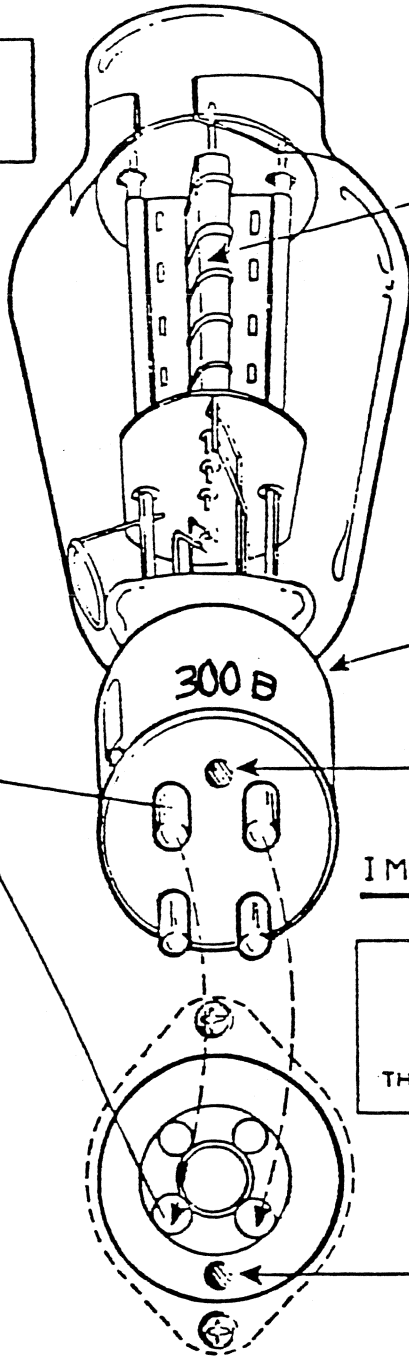

CAD-300SEI
INTEGRATED SINGLE-ENDED TRIODE STEREO AMPLIFIER

SPECIFICATIONS

WEIGHT: 42 lbs. shipping weight
DIMENSIONS: 8"H x 14"W x 14"D
CIRCUIT TYPE: Single-ended, Class A
POWER OUTPUT: 4/8 ohms = 11 watts/CH
S/N: 90dB below rated power output
FREQUENCY RESPONSE (11 watt): 23 - 20,000 Hz (+0 - 0.75dB)
HEADPHONE OUTPUT: 4-50 ohm compatible 1/4" 3 circuit jack
RESISTOR: 1% metal film
OUTPUT TRANSFORMER: 200% duty cycle
Air gapped, wound with OFC
copper wire, wax impregnated
WIRE: Silver double "E" teflon
COUPLING CAPS: Oil filled
POWER SUPPLY CAPACITORS: 2 - 1200MFD @ 450VDC,
TOTAL = 2400MFD - 230 Joules
WIRING: Point-to-point
LINE INPUT: 3 switchable selections
SPEAKER POSTS: Eddison Price copper
TUBE SOCKETS: Ceramic silver pins
ADDITIONAL FEATURES: Soft shoe feet
Detachable power cord
TUBE COMPLIMENT: 2 - 300B triode output tubes in
Class A single-ended
3 - 6SN7 input driver tubes
WARM-UP TIME: 3 minutes
BREAK-IN PERIOD: 100 hours of music playing time
FINISH: Stainless steel chrome chassis with
high gloss anodized black front panel.
(24 Karat Gold front panel & knobs optional)
OPTIONAL: PH-300 MC,MM phono stage

NOTE: Specifications are subject to change without notice or obligation.

UNITED STATES LIMITED WARRANTY

Cary Audio Design, Inc. warrants to the original United States purchaser for use in the United States, that this product shall be free from defects in material (except tubes and AF output transistors) or workmanship for three (3) years from the date of the original purchase.

During the warranty period, Cary Audio Design, Inc. or an authorized Cary Audio Design, Inc. service facility will provide free of charge both parts (except tubes and AF output transistors) and labor necessary to correct defects in material or workmanship.

To obtain such warranty service, the original purchaser must:

- (1) Complete and send in the warranty Registration Card.
- (2) Notify Cary Audio Design, Inc. as soon as possible after the discovery of a possible defect, of:
 - (a) The model number and serial number;
 - (b) The identity of the seller and the approximate date of purchase;
 - (c) A detailed description of the problem, including details on the electrical connection in the associated equipment and the list of such equipment.
- (3) Deliver the product to Cary Audio Design, Inc. or the nearest authorized service facility, or ship the same in its original container or equivalent, fully insured and the shipping charges prepaid.

Correct maintenance, repair and use are important to obtain performance from this product. Therefore, carefully read the Instruction Manual. This warranty does not apply to any defect that Cary Audio Design, Inc. in its sole discretion determines is due:

- (1) Improper maintenance or repair, including the installation of parts or accessories that does not conform to the quality and the specifications of the original parts.
- (2) Misuse, abuse, neglect or improper installation.
- (3) Accidental or incidental damage.

WARRANTY DISCLAIMER

Except for the express warranties stated herein, Cary Audio Design, Inc. disclaims all other warranties including, without limitation, all implied warranties of merchantability and fitness for a particular purpose.

EXCLUSIVE REMEDY

Notwithstanding the foregoing, the purchaser's exclusive remedy for any breach of warranty, express or implied, is limited to the repair or replacement of the defective unit or the refund of the purchase price, at the option of Cary Audio Design, Inc. Under no circumstances is Cary Audio Design liable for incidental or consequential damages. Any implied warranties imposed by law terminate one (1) year from the date of the original purchase.

FOREIGN PURCHASERS

Cary Audio Design, Inc. warrants its merchandise to purchasers in the United States for use in the United States. It provides no other warranties. If you are a foreign purchaser, consult with your dealer to determine whether your dealer provides any warranty.

The foregoing constitutes Cary Audio Design, Inc.'s entire obligation with respect to this product, and the original purchaser and any user or owner shall have no other claim for incidental or consequential damages. Some states do not allow the exclusion or limitation of incidental or consequential damages, so the above limitation and exclusion may not apply to you.

This warranty gives legal rights and you may also have other rights which vary from state to state.