

**CARY**<sup>®</sup>  
*Audio Design*  
INC.

**CAD300M**

CLASS A MONO BLOC

## OPERATING MANUAL



**NOTE:**

Before installing your new CAD-300M, please read this manual carefully as it will inform you of the CAD-300M's specifications, proper installation procedures and operation procedures. Also included in this manual are guidelines on how to properly service and care for your new CAD-300M.

#### UNITED STATES LIMITED WARRANTY

Cary Audio Design, Inc. warrants to the original United States purchaser for use in the United States, that this product shall be free from defects in material (except tubes and AF output transistors) or workmanship for three (3) years from the date of the original purchase.

During the warranty period, Cary Audio Design, Inc. or an authorized Cary Audio Design, Inc. service facility will provide free of charge both parts (except tubes and AF output transistors) and labor necessary to correct defects in material or workmanship.

To obtain such warranty service, the original purchaser must:

- (1) Complete and send in the warranty Registration Card.
- (2) Notify Cary Audio Design, Inc. as soon as possible after the discovery of a possible defect, of:
  - (a) The model number and serial number;
  - (b) The identity of the seller and the approximate date of purchase;
  - (c) A detailed description of the problem, including details on the electrical connection in the associated equipment and the list of such equipment.
- (3) Deliver the product to Cary Audio Design, Inc. or the nearest authorized service facility, or ship the same in its original container or equivalent, fully insured and the shipping charges prepaid.

Correct maintenance, repair and use are important to obtain performance from this product. Therefore, carefully read the Instruction Manual. This warranty does not apply to any defect that Cary Audio Design, Inc. in its sole discretion determines is due:

- (1) Improper maintenance or repair, including the installation of parts or accessories that does not conform to the quality and the specifications of the original parts.
- (2) Misuse, abuse, neglect or improper installation.
- (3) Accidental or incidental damage.

#### **WARRANTY DISCLAIMER**

Except for the express warranties stated herein, Cary Audio Design, Inc. disclaims all other warranties including, without limitation, all implied warranties of merchantability and fitness for a particular purpose.

#### **EXCLUSIVE REMEDY**

Notwithstanding the foregoing, the purchaser's exclusive remedy for any breach of warranty, express or implied, is limited to the repair or replacement of the defective unit or the refund of the purchase price, at the option of Cary Audio Design, Inc. Under no circumstances is Cary Audio Design, Inc. liable for incidental or consequential damages. Any implied warranties imposed by law terminate one (1) year from the date of the original purchase.

#### **FOREIGN PURCHASERS**

Cary Audio Design, Inc. warrants its merchandise to purchasers in the United States for use in the United States. It provides no other warranties. If you are a foreign purchaser, consult with your dealer to determine whether your dealer provides any warranty.

The foregoing constitutes Cary Audio Design, Inc.'s entire obligation with respect to this product, and the original purchaser and any user or owner shall have no other claim for incidental or consequential damages. Some states do not allow the exclusion or limitation of incidental or consequential damages, so the above limitation and exclusion may not apply to you.

This warranty gives legal rights and you may also have other rights which vary from state to state.

# Notes

## CAD-300M Triode Mono Bloc Amplifiers

### INTRODUCTION

Congratulations! You have purchased one of the most exotic audio amplifiers available. The CAD-300M mono block amplifiers redefine the characteristics and operating parameters of a true "high-end" amplifier. Careful design, parts selection and proper circuit topologies contribute to incredible reliability and enjoyment.

For the technically minded, a review of the circuit is in order. Your new CAD-300M operates in a class A mode utilizing regulated fixed bias on the 300B output tubes. The 300B triode tube in the CAD-300M is a REAL triode audio tube. These output tubes offer far greater linearity and lower distortion than the tetrode or pentode audio output tubes. The 300B output tubes are operating in a push-pull configuration utilizing a special OFC wound output transformer. The output transformers in your CAD-300M is the most important component in the amplifier and has been specifically designed by Cary Audio for use in the CAD-300M. Negative feedback is NOT used. This is a zero feedback design. The power supply in the CAD-300M features a 150% duty cycle EI laminate power transformer. The high voltage section features full wave rectification (not cheap voltage doublers used in many amplifiers ) to a PI-L capacitor network. The fullwave rectification is provided by one 5U4/CV-378 rectifier tube. The use of tube rectification is an assurance of slow B+ turn on during tube warm up. To avoid AC hum, the input and phase inverter 6SN7 tubes have DC regulated filament voltage. This will prevent AC ripple voltage from capacitively being coupled to electrodes in the gain stage of the 6SN7's. The input signal from the input jack is direct coupled to the first grid of the 6SN7. There are no coupling capacitors in line with the input signal on the CAD-300M.

## 300M Bias Adjustment & Tube Placement

A great deal of attention during design of your new CAD-300M was concentrated on the "overload recovery" ability of the amplifier. The ability of an amplifier to instantly recover from clipping is much more important than is commonly believed. In the power war of amplifier manufacturers the mentality is focused on high and then even higher power output to solve the clipping problem. When in reality the most critical aspect is how fast a recovery an amplifier can achieve after overload. With the incredible dynamic range of live and in turn recorded music, even 2,000 watts of power is not enough. Most of the music being listened to in an average listening room is only requiring about 3 watts of power. It is on the transients of loud low frequency program material that tremendous signal voltages will appear at the input of the amplifier. It is in this situation that the overload recovery ability of an amplifier is of critical concern. The CAD-300M extols its merits in the ability to handle transients and instantaneously recover from brief or even extended overloads. The CAD-300M will also yield faithful reproduction of extremely low frequencies at full output levels. Power transformer, power supply regulation and output transformer design and careful shaping of the overall frequency response curve all play a very important part in the ability of the CAD-300M to recover quickly when overloaded. If one were to monitor the high voltage rail voltage (430VDC) of a CAD-300M during soft and also loud music passages it will be found there is no more than a volt or so change from soft to loud passages.

Another technical feature of your new CAD-300M is amplifier stability. The CAD-300M may be operated with no load (without speaker) without damage to the amplifier, output transformer or tubes.

The most exciting feature of the CAD-300M mono bloc amps, aside from how compact and gorgeous they look, is the delightful, sensual beauty of the music it recreates. The first thing that will strike you about your new CAD-300M mono bloc amplifier is the incredible transparency and resolution of detail in the music. The CAD-300M's sensual nature is best revealed in the sense of life it displays in female vocalists.

Your new CAD-300M amplifier presents music with such presence and directness, you'll be drawn into the music hour after musically satisfying hour. This is the result of circuit techniques, which eliminate any discernible crossover notch at low levels, and also contributes to the freedom from listening fatigue. The CAD-300M will draw you in even further as you realize how lucid and utterly uncolored neutrality reveals delicate nuances in the sound stage.

Please read this complete manual for a complete understanding of trouble free operation, and ENJOY THE MUSIC !

Adjust bias pot until meter reads 225mA

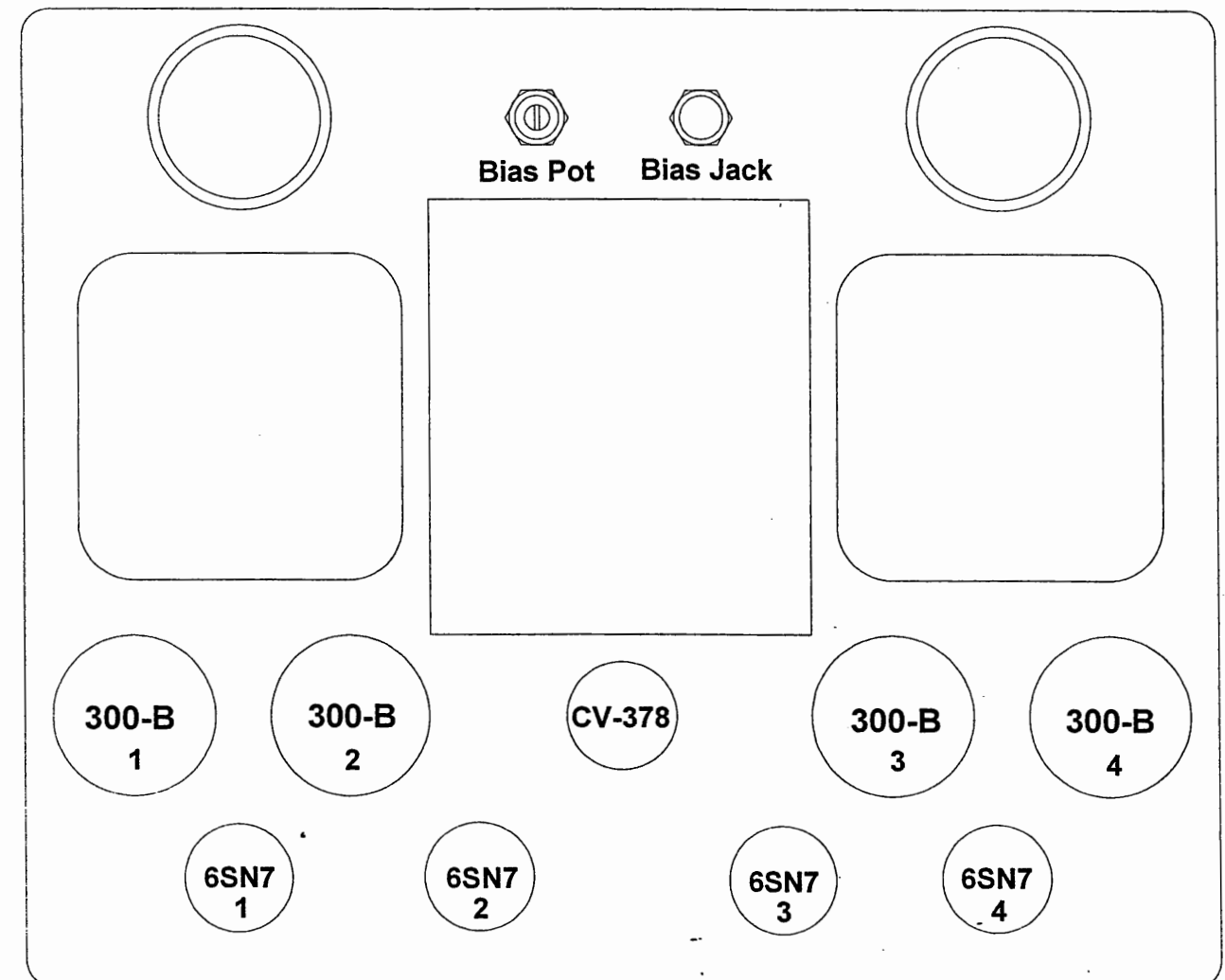
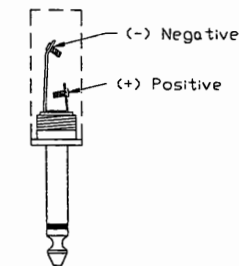
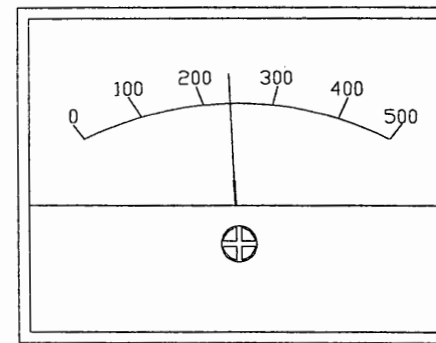

Insert meter plug into bias jack.  
Adjust for 225mA reading on VOM or DC current meter.  
Readjust after after 300-M has warmed up for 10 minutes.  
Remove plug and enjoy the music!

### WARNINGS

**MAKE NO ATTEMPT TO PUT THE CAD-300M IN SERVICE WITH THE BOTTOM COVER REMOVED. CONTACT WITH HIGH VOLTAGES FOUND IN THE UNIT CAN BE FATAL !!!**

**COMPLETELY REMOVE AC POWER PLUG FROM THE WALL AND ALLOW 30 MINUTES FOR THE HIGH VOLTAGE CAPACITORS TO DISCHARGE THROUGH BLEEDER RESISTORS BEFORE ATTEMPTING TO CHANGE TUBES OR CLEAN THE INSIDE OF THE AMPLIFIER.**

### CAUTIONS

**NEVER REMOVE/INSERT AC PLUG WHEN THE UNIT IS ON OR THE AC POWER SWITCH IS IN THE "ON" POSITION.**

**obstruction OF THE TOP PORTION OF THE CAD-300M WILL RESULT IN TUBES OVERHEATING.**

**\*\*\*OBSERVE DIRECTIONS IN THIS MANUAL\*\*\***

### SPECIFICATIONS

Operating the CAD-300M amplifier is a simple procedure since each unit is designed for long term stability in virtually any home operating situation. Therefore, if the unit is operated outside the parameters outlined in this owner's manual, damage may result. Please read this manual carefully before putting your new Cary Audio Design CAD-300M in operation.

The following definitions are applicable to this manual. These definitions must be followed explicitly.

**WARNING  
HAZARD PRESENTS PERSONAL INJURY OR DEATH**

**CAUTION  
EQUIPMENT DAMAGE MAY OCCUR BUT NOT PERSONAL INJURY**

**Note  
proper performance of the amplifier cannot be ensured if disregarded**

### 1.2 Specifications

The following section describes each of the CAD-300M's basic specs. Specifications are subject to change without notice or obligation.

DIMENSIONS: 6" x 17"W x 13.5"D

WEIGHT: 38Lbs.

CIRCUIT TYPE: Push-Pull in Class A

INPUT SENSITIVITY: .750 volts for full output

INPUT IMPEDANCE: 150.000 ohms

NOISE AND HUM: (at one watt output): 9Hz to 30,000Hz + 0 - 0.75dB  
(at full power output): 21Hz to 19,000Hz + .5 - 0.50dB

DAMPING FACTOR: Greater than 30

TUBES: 2-6SN7 predrivers, 2-6SN7 Phase Inverters, 4-300B triode output, 1-5U4/CV378 rectifier

TRANSFORMERS: 1-EI laminated core power transformer  
2-Special EI laminate OFC copper output transformers  
150% duty cycle on all transformers

RESISTORS: 1% metal film

CAPACITORS: Polystyrene and polypropylene

POWER SUPPLY CAPACITORS: 3-1100 MFD @ 450OVDC, 223 Joules

AC CORD: 3 conductor shielded-detachable

AC POWER REQUIREMENTS: 117 volts AC 50/60 Hz  
295 watts operate  
90 watts in stand by  
220 volts AC 50/60 Hz  
295 watts operate  
90 watts in stand by

WARM-UP TIME: 3 minutes

BREAK-IN PERIOD: 100 hours of music playing time.

FINISH: Nickel chrome plated stainless steel.

### 1.3 Front Panel Features

AC-ON SWITCH: Turns AC power on in the "up" position

STAND BY SWITCH: Turns B+ high voltage "on" or "off"

## SERVICE AND CARE

### 4.1 CAD-300M Care and Cleaning

The chassis of the CAD-300M may be cleaned with a soft rag and Windex (or a similar window cleaner). The frequency of cleaning will be governed by how many hours the CAD-300M is operated and by operating environmental cleanliness.

### 4.2 Tube Replacement

If it is necessary to replace the tubes in the CAD-300M amplifier, a matched set of tubes of the same brand should be used. A new tube kit is available from Cary Audio Design, Inc. You should get years from the output tubes with everyday usage and many, many years of use from the 6SN7 input tubes and 5U4/CV378 rectifier tubes.

### 4.3 Factory Service

Careful consideration has been given to the design of your CAD-300M amplifier to keep maintenance problems to a minimum. However, it is possible that some problems may arise which cannot be cured by tube substitution. At this point we suggest that you contact our Customer Service Department, phone number 1-800-421-5456, to describe your problem in detail. Do not return the CAD-300M to the factory without a return authorization number from the Customer Service Department. Cary Audio Design, Inc. will assume no responsibility if the transportation company refuses to pay a damage claim due to your improper packing or lack of insurance should the unit be lost in shipment.

### 3.2 AC On Power Switch

Simply push the AC rocker switch up to the ON position. The Blue "300B" on the front panel will light.

### 3.3 Stand-By Switch

This is a most convenient feature on the CAD-3000M amplifier. In the "up" position, the amplifier is ready to operate. In the "down" position (provided the front panel AC switch is in the "on" position), only the tube filaments are operating. You may wish to leave your CAD-300M amplifier turned on in the stand-by mode 24 hours a day. When you wish to listen to music, simply flip the stand-by switch in the "up" position. Under these conditions the CAD-300M is always warmed up and ready for peak performance.

### 3.4 Break in Period

The tubes, capacitors and output transformers take approximately 100 hours of music playing to fully settle in for peak performance. The CAD-300M may seem sterile or thin sounding right out of the box. After the first couple of hours you will notice increased depth and tighter bass. This break in period defies all engineering theory, but is true with most audio amplifiers.

**WARNING**  
**MAKE SURE AMPLIFIER IS UNPLUGGED FROM AC MAINS**  
**FOR ANY SERVICE OR CLEANING !**

### 1.4 Rear Apron Features

INPUT: Signal input connection via shielded interconnect cable

OUTPUT: The 5-way binding posts provide the output to the speaker system.  
Red= +, Black= -

**CAUTION**  
**EQUIPMENT DAMAGE MAY OCCUR WITH IMPROPER FUSES**

AC: 3 conductor shielded power cord to AC power mains.

**CAUTION**  
**USE OF ANY OTHER PROTECTION FUSE CAN DAMAGE UNIT**

FUSE AC power fuse. Never replace with any other valve than 3 AMP  
SLOW BLOW ! 250 VOLT ! (250 VAC units use 1-1/2 amp fuse).

GND: For "audio-purists" this should be connected to an earth ground rod via the shortest lead possible - this is not essential for proper operation. The earth ground will help insure immunity to RF interference and AC ground loops.

**CAUTION**  
**NEVER REMOVE/INSERT AC LINE CORD WHEN THE UNIT IS ON**

TUBE FUSE: This is an overcurrent protection fuse for the output tubes. Never replace with any other valve than 1/2 AMP  
FAST BLOW! 250 VOLT!

**TO INSTALL THE 300B TUBES, REFER TO TUBE OUTLINE DRAWING AT THE BEGINNING OF THIS MANUAL !**

## INSTALLATION

This section describes the unpacking and installation procedures for the CAD-300M mono bloc amplifiers.

### **WARNING**

**MAKE NO ATTEMPT TO PUT THE CAD-300M AMPLIFIERS IN SERVICE WITHOUT THE BOTTOM PLATE ATTACHED - CONTACT WITH VOLTAGE IN THE CAD-300M CAN BE FATAL !!**

### **2.2 Unpacking**

All shipping containers have been specifically designed to protect their contents and special care has been taken to prevent damage under normal shipping conditions. Mishandling should be evident upon inspection of the shipping container. If damage is found after visual inspection, take care not to destroy the evidence. If necessary, document the damage with photographs and contact the transport carrier immediately.

Carefully remove your new CAD-300M amplifiers from its packing carton, and examine it closely for signs of shipping damage. It is recommended to save all original packing cartons to protect your amplifier from damage should you wish to store it or ship it for after sales service.

### **2.3 Warranty Card**

Fill out the enclosed warranty registration card and return to Cary Audio Design, Inc. within 10 days of original purchase. Keep your original sales slip with the packing cartons should you ever need it for reference. **Failure to register warranty will limit the warranty to one year.**

### **2.4 Amplifier Placement**

In general, the location of your new CAD-300M amplifiers is not critical. The best placement in your system is near the speaker system with short lengths of speaker cables. Certain precautions must be taken to ensure optimum performance. Avoid extremely hot locations such as near radiators or other heating units. Keep the top of the CAD-300M clear of books, paper or other equipment to protect against overheating. **DO NOT PLACE CAD-300M MONO BLOCS IN A CLOSED BOOKCASE - OVERHEATING WILL SEVERELY DAMAGE THE AMPLIFIER !!!**

### **2.5 Power Requirements**

The CAD-300M is designed to operate from house current mains. The design voltage is 117VAC at 50/60Hz. (Foreign units 220 VAC at 50/60Hz).

### **2.6 Cables**

The speaker cables from the output posts of the CAD-300M to the speaker system can be any convenient length your set-up requires. Select speaker cables of sufficient size to preserve the outstanding performance capabilities of your CAD-300M. Heavy gauge #16 wire is suitable for distances up to 10 feet ; #12 for 25 feet. Most audio dealers will have proper speaker cable in stock for this purpose.

## OPERATION

Signal input connections are made via the input jack on the rear of the CAD-300M located next to the output binding posts. The interconnect cables from the output of the preamplifier can be any convenient length your set-up requires. The choice of a high quality interconnect cable is important. Once again, your audio dealer will have the proper cables in stock for this purpose.

### **3.1 Operation**

Your new CAD-300M is ready for operation after the speaker , interconnect cables and all the tubes have been installs. **Refer to the tube outline drawing at the end of this manual for tube placement.**