



CAD-2A3i

OPERATING MANUAL

NOTE:

Before installing your new SLI -50, please read this manual carefully as it will inform you of the *CAD-2A3I*'s specifications, proper installation procedures and operation procedures. Also included in this manual are guidelines on how to properly service and care for your new *CAD-2A3I*.

CAD-2A3

INTEGRATED AMPLIFIER

Congratulations! You have purchased one of the most exotic audio amplifiers available. Within its power range, the CAD-2A3 displays the operating characteristics of a true “high-end” amplifier. Careful design, parts selection and proper circuit topologies contribute to incredible reliability and enjoyment.

For the technically minded, a review of the circuit is in order. Your new CAD-2A3 operate in a class AB1 mode close to class A. In fact most of your listening levels will be in the class A mode. The output stage 2A3 tubes are biased with a negative fixed bias voltage for low distortion and maximum output capabilities. The CAD-2A3 is a true triode push-pull amplifier. A properly designed triode amplifier is the most linear and yields the most musically satisfying presentation. The output power is 10 plus watts of triode power. The output transformers on the CAD-2A3 is the most important component in the amplifier and has been specifically designed by Cary Audio for use in the 2A3. We have taken the approach in the output transformer design not to dissimilar to the single-ended amplifiers we design and produce. The primary and secondary windings on portions of the output transformer are wound in a bi-filer process with the two inductors interleaving sixteen times. The bi-filer wind (two conductors wound at the same time) will yield the closest balance and coupling of any designed currently utilized in vacuum tube output transformers. The E/I laminents used are silicone impregnated hipersil steel contributing to the extremely low loss of the CAD-2A3 output transformer. The above process is similar to the single-ended design without the air-gap found on the Cary single-ended output transformers. A small amount (-1dB) of negative feedback is utilized to improve speaker damping. The CAD-2A3 original engineering design was done with zero feedback so you can be assured that the feedback circuit is **not** implemented to correct distortion and transient response. A balanced drive signal is applied to the control grids of the 2A3 output tubes from the 6SN7 driver tube. This tube is configured in a dual differential network that operates in the following manner: The first section of the dual 6SN7 tube is direct coupled to the input pre-driver stage. The drive signal is amplified through this first section in a class A grid driven circuit with the

output signal inverted 180 out of phase at the anode and then coupled to one half of the push-pull bank of 2A3's. At the same time the second half of the dual triode 6SN7 is cathode driven in a grounded grid non-inverting class A gain stage coupled to the other half of the push-pull bank of 2A3's. With this network the balance is a perfect plus and minus dual drive signal to drive the final output 2A3's in a balanced push-pull. The input pre-drive stage is the first 12AU7 dual triode on the CAD-2A3. This first stage is identical to the Cary Audio single-ended amplifiers. This first pre-drive stage is a single-ended class A anode current source gain stage. The input signal from the selector switch and volume control is direct coupled to the grid of one section of the 12AU7 input tube. The anode of this section is direct couple to the cathode/grid of the second stage. This second stage takes the place of the conventional dropping/coupling resistor network found in conventional gain stages. This is called the anode current section and offers infinite resistance and the proper current/voltage to operate the gain stage. The amplified signal is then direct coupled to the other 6SN7 which drives the 2A3's in the balanced configuration as described earlier.

The power supply transformer is designed to operate at a 150% continuous commercial service at the full rated 20 watt output level. The high voltage power supply section is a full wave center tap configuration (not some cheap voltage doubler as used in many competitors amps) to a PI network with a filter choke. This high voltage section feeds the final output 2A3's. Another supply is the negative DC grid bias circuit that once again is a PI network. A regulated filament supply will prevent AC ripple from capacitively being coupled to the electrodes in the 12AU7 and 6SN7 gain stages.

A great deal of attention during design of your new CAD-2A3 was concentrated on the "overload recovery" ability of the amplifier. The ability of an amplifier to instantly recover from clipping is much more important than is commonly believed. In the power war of amplifier manufactures the mentality is focused on high and then even higher power output to solve the clipping problem. When in reality the most critical aspect is how fast of a recovery an amplifier can achieve after overload. With the incredible dynamics range of live and in turn recorded music, even 2,000 watts of power is not enough. Most of the music being listen to in an average home listening room is only requiring about 3 watts of power. It is on the

transients of loud low frequency program material that tremendous signal voltages will appear at the input of the amplifier. It is in this situation that the overload recovery ability of an amplifier is of critical concern. The CAD-2A3 extols its merits in the ability to handle transients and instantaneously recover from brief or even extended overloads. The CAD-2A3 will overload symmetrically at any frequency in the audio bandpass. The CAD-2A3 will also yield faithful reproduction of extremely low frequencies at full output levels. Power transformer, power supply regulation and output transformer design and careful shaping of the overall frequency response curve all play a very important part in the ability of the CAD-2A3 to recover quickly when over loaded. If one were to monitor the high voltage rail voltage (325 VDC) of the CAD-2A3 during soft and also loud music passages it would be found there is no more than a volt or so change from soft to loud passages.

Another technical feature of your new CAD-2A3 amplifier is stability. The CAD-2A3 maybe operated with no load (without speaker) without damage to the amplifier, output transformer or tubes.

SPECIFICATIONS

Operating the CAD-2A3i stereo integrated amplifier is a simple procedure, since each unit is designed for long term stability in virtually any home operating situation. Therefore, if the unit is operated outside the parameters outlined in this owner's manual, damage may result. Please read this manual carefully before putting your new Cary Audio Design CAD-2A3i in operation. The following definitions are applicable to this manual. These definitions must be followed explicitly.

WARNING
HAZARD PRESENTS PERSONAL INJURY OR DEATH

Caution
EQUIPMENT DAMAGE MAY OCCUR BUT NOT PERSONAL INJURY

Note
Proper performance of the amplifier cannot be ensured
if disregarded

1.2 Specifications

The following section describes the CAD-2A3i basic specifications. Specs are subject to change without notice or obligation.

DIMENSIONS: 7"H x 17"W x 16"D

WEIGHT: 42 lb..

CIRCUIT TYPE: Push-Pull Ultralinear Amplification in Pure Class AB

POWER OUTPUT: 15 Watts Triode, 50 Watts Tetrode

INPUT SENSITIVITY: .75 volts for full output

INPUT IMPEDANCE: 100,000 ohms

NOISE AND HUM: 82db below rated output

FREQUENCY RESPONSE (at full power output): 19Hz to 20Khz +/- 1db

TUBES: 2- 12AU7 Input Buffer Preamp
2- 6SN7 Pre-Driver/Phase Inverter
4- 2A3 Output tubes
2- CV729/5U4 Rectifiers

POWER TRANSFORMERS: 1- EI laminated, 200% duty cycle

OUTPUT TRANSFORMERS: 2-EI laminated, Silicon Impregnated

RESISTORS: 1% metal film

CAPACITORS: Oil Filled

POWER SUPPLY CAPACITORS: 2 - 1200 MFD @ 450 volts
2 - 10 MFD @ 450 volts film & foil

AC CORD: 3 conductor shielded detachable

AC POWER REQUIREMENTS: 117/234 volts AC 50/60Hz

POWER CONSUMPTION: 120 watts operate
78 watts in stand-by

WARM-UP TIME: 3 minutes

BREAK-IN PERIOD: 100 hours of music playing time

FINISH: Chrome plated Stainless Steel Chassis

FRONT PANEL: Machined, Gold Anodized aluminum

1.3 Front Panel Features

POWER ON, STAND BY, OPERATE: Rotary switch turns on AC mains and high voltage on "in operate" position

LED: Indicates high voltage on

VOLUME: Dual precision potentiometer controlling volume of both channels

BALANCE: Dual precision potentiometer to balance between left and right channel

SELECTOR: Selection of line inputs for listening. Direct, CD, AUX 1, & AUX 2
(Direct input by-passes volume and balance controls. Must use external volume control)

1.4 Rear Apron Features

INPUTS Direct, CD, AUX1, & AUX 2: Signal input connection via shielded interconnect cable

TAPE OUT: Steady level output to recorder input

SPEAKER OUTPUT: 5-way binding posts provide the output to the speaker system. Red = +, Black = -

AC: 3- conductor shielded power detachable cord to AC power mains.

CAUTION
EQUIPMENT DAMAGE MAY OCCUR WITH IMPROPER FUSES

AC FUSE: This is an over current protection fuse for the CAD-2A3i.
Never replace with any other fuse than 3 AMP SLOW BLOW!
250 VOLT! (2 AMP SLOW BLOW ON 220 VAC OPERATION)

TUBE FUSE: This is a protection fuse for the output tubes. Never replace with any other fuse than a .5 amp fast blow! 250 volt.

CAUTION
NEVER REMOVE / INSERT AC LINE CORD WHEN THE UNIT IS ON

INSTALLATION

This section describes the unpacking and installation procedures for the CAD-2A3i amplifier.

WARNING
MAKE NO ATTEMPT TO PUT THE CAD-2A3i AMPLIFIER IN
SERVICE WITHOUT THE BOTTOM PLATE ATTACHED - CONTACT WITH
VOLTAGE
IN THE CAD-2A3i CAN BE FATAL!!!!

2.1 Unpacking

All shipping containers have been specifically designed to protect their contents and special care has been taken to prevent damage under normal shipping conditions. Mishandling should be evident upon inspection of the shipping container. If damage is found after visual inspection, take care not to destroy the evidence. If necessary, document the damage with photographs and contact the transport carrier immediately.

Carefully remove your new CAD-2A3i stereo integrated amplifier from its packing carton, and examine it closely for signs of shipping damage. It is recommended to save all original packing cartons to protect your amplifier from damage should you wish to store it or ship it for after-sales service.

2.2 Warranty Card

Fill out the enclosed warranty registration card and return it to Cary Audio Design, Inc. within 10 days of original purchase. Keep your original sales slip with the packing cartons should you ever need it for reference. **Failure to register warranty will limit the warranty to one year.**

2.3 Amplifier Placement

In general, the location of your new CAD-2A3i is not critical. Certain precautions must be taken to ensure optimum performance. Avoid extremely hot locations such as near radiators or other heating units. Keep the top of the CAD-2A3i clear of books, paper or other equipment to protect against overheating!! **DO NOT** place your CAD-2A3i in a closed book case - overheating will damage the amplifier! Allow 8 to 10 inches above the unit for proper ventilation.

2.4 Power Requirements

The CAD-2A3*i* is designed to operate from house current mains. The design voltage is 117 VAC at 50/60Hz. (Foreign units 234 VAC at 50/60Hz.)

2.5 Cables

The speaker cables from the output posts of the CAD-2A3*i* to the speaker system can be any convenient length your set-up requires. Select speaker cables of sufficient size to preserve the outstanding performance capabilities of your CAD-2A3*i*. Heavy gauge #16 wire is suitable for distances up to 10 feet; #12 for 25 feet. Most audio dealers will have proper speaker cable in stock for this purpose.

OPERATION

Signal input connection is made via the input jacks on the rear of the CAD-2A3*i* located on the rear panel. The interconnect cables from the output of the CD player, tuner, etc. can be any convenient length your set-up requires. The choice of a high quality interconnect cable is important. Once again, your audio dealer will have the proper cables in stock for this purpose.

3.1 Operation

Your new CAD-2A3*i* is ready for operation after the speaker and interconnect cables and tubes have been installed.

3.2 AC On Stand By Power Switch

Simply turn the rotary switch to the "stand by" position. Observe that all 10 tubes are lit (filaments). After 1 to 2 minutes turn the switch to "operate". The high voltage will slowly come up and the blue LED will light and indicate the power supply is charged. Waiting 1 to 2 minutes before switching to "operate" is not absolutely necessary, but warming up the filaments before applying high voltage will extend the life of your tubes.

3.3 Stand By Switch

This is a most convenient feature on the CAD-2A3*i* amplifier. In the "operate" position, the amplifier is ready to operate. In the "stand by" position, only the tube filaments are operating. You may wish to leave your CAD-2A3*i* amp turned on in the "stand by" mode 24 hours a day. When you wish to listen to music simply turn the stand by switch to the operate position. Under these conditions the CAD-2A3*i* is always warmed up and ready for peak performance.

3.4 Break-In Period

The tubes, capacitors and output transformers take approximately 100 hours of music playing to fully settle in for peak performance. The CAD-2A3*i* will seem sterile or thin sounding right out of the box. After the first couple of hours you will notice increased depth and tighter bass. This break-in period defies all engineering theory, but is true with most audio amplifiers.

WARNING
MAKE SURE AMPLIFIER IS UNPLUGGED FROM AC MAINS BEFORE
SERVICING

SERVICE AND CARE

4.1 CAD-2A3*i* Care and Cleaning

The case and front of the CAD-2A3*i* may be cleaned with a soft cloth and Windex or a window cleaner. The frequency of cleaning will be governed by how many hours the CAD-2A3*i* is operated and by operating environment cleanliness. A very mild chrome polish may be used on the chrome chassis to remove what the window cleaner does not. **CAUTION!** Gently apply the polish to the chrome, otherwise you may scratch the chassis.

4.2 Tube Replacement

If it becomes necessary to replace the tubes in the CAD-2A3*i* amplifier, a matched quartet set of output tubes of the same brand should be used. A new tube kit is available from Cary Audio Design, Inc. You should get a few years or more from the output tubes with everyday usage and many, many years of use from the 12AU7 & 6SN7 input tubes.

4.3 FACTORY SERVICE

Careful consideration has been given to the design of your CAD-2A3*i* amplifier to keep maintenance problems to a minimum. However, it is possible that some problems may arise which cannot be cured by tube substitution. At this point we suggest you contact our Customer Service Department phone number (919)481-4494 to describe your problem in detail. **DO NOT** return the CAD-2A3*i* to the factory without a return authorization number from the Customer Service Department.

Cary Audio Design, Inc. will assume no responsibility if the transportation company refuses to pay a damage claim due to your improper packing or lack of insurance should the unit be lost or damaged in shipment.

WARNINGS

MAKE NO ATTEMPT TO PUT THE CAD-2A3i IN SERVICE WITH THE BOTTOM PLATE REMOVED. CONTACT WITH HIGH VOLTAGES FOUND IN THE UNIT CAN BE FATAL!! COMPLETELY REMOVE AC POWER PLUG FROM THE WALL AND ALLOW 30 MINUTES FOR THE HIGH VOLTAGE CAPACITORS TO DISCHARGE THROUGH BLEEDER RESISTORS BEFORE ATTEMPTING TO CHANGE TUBES OR CLEAN THE INSIDE OF THE AMPLIFIER

CAUTIONS

NEVER REMOVE / INSERT AC PLUG WHEN THE UNIT IS ON OR THE AC POWER SWITCH IS IN THE ON POSITION. OBSTRUCTION OF THE TOP PORTION OF THE CAD-2A3i WILL RESULT IN TUBES OVERHEATING AND DAMAGE TO THE AMPLIFIER.

!!OBSERVE DIRECTIONS IN THIS MANUAL!!

CAD-2A3i TROUBLESHOOTING GUIDE

SYMPTOM

CAUSE

REMEDY

Hum or "Buzzing" through speakers	-Ground Loop	-Install 2-pin adapter on AC cord to float the ground.
	-Intermittent or poor connection of interconnect ground	-Replace interconnect.

"Popping or Spitting" noise through the speaker	-Noisy tube	-If noise is in one channel, swap one section of tubes at a time until the noise swaps channels. Replace noisy tube.
		-Check bias of output tubes. If high or fluctuating rapidly, replace output tube. (See bias instruction sheet)
AC fuse blows	-Line voltage surge	-Replace fuse.
	-CV729 shorted.	-Replace CV729

Tube fuse blows	-Shorted 2A3	-Replace tube.
-----------------	--------------	----------------

CAD-2A3i Bias Adjustment

Bias Meter Jack

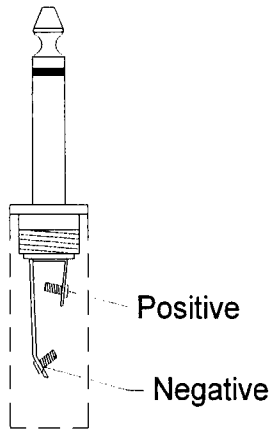
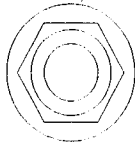

Bias Adjust

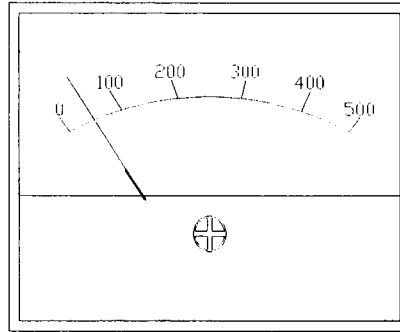
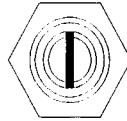

Set bias for both sides of the amplifier to 50mA

Insert meter plug into bias jack.
Adjust for 50mA reading on VOM or DC current meter.
Readjust to 50mA after after CAD-2A3i is warmed up
for 10 minutes. Remove plug and enjoy the music!

Note: Bias is factory preset; Bias should be reset when installing replacement 2A3 tubes.

UNITED STATES LIMITED WARRANTY

Cary Audio Design, Inc. warrants to the original United States purchaser for use in the United States, that this product shall be free from defects in material (except tubes and AF output transistors) or workmanship for:

Models CAD-211M, SLM-200 and the CAD-805, Five (5) years from date of original purchase.

Amplifiers and Preamplifiers, Three (3) years from the date of the original purchase.

Digital Products, One (1) year from original date of purchase.

During the warranty period, Cary Audio Design, Inc. or an authorized Cary Audio Design, Inc. service facility will provide free of charge both parts (except tubes and AF output transistors) and labor necessary to correct defects in material or workmanship.

To obtain such warranty service, the original purchaser must:

- (1) Complete and send in the warranty Registration Card.
- (2) Notify Cary Audio Design, Inc. as soon as possible after the discovery of a possible defect:
 - (a) The model number and serial number;
 - (b) The identity of the seller and the approximate date of purchase;
 - (c) A detailed description of the problem, including details on the electrical connection in the associated equipment and the list of such equipment.
- (3) Deliver the product to Cary Audio Design, Inc. or the nearest authorized service facility, or ship the same in its original container or equivalent, fully insured and the shipping charges prepaid.

Correct maintenance, repair and use are important to obtain optimum performance from this product. Therefore, carefully read the Operating Manual. This warranty does not apply to any defect that Cary Audio Design, Inc. in its sole discretion determines is due to:

- (1) Improper maintenance or repair, including the installation of parts or accessories that does not conform to the quality and the specifications of the original parts.
- (2) Misuse, abuse, neglect or improper installation.
- (3) Accidental or incidental damage.

WARRANTY DISCLAIMER

Except for the express warranties stated herein, Cary Audio Design, Inc. disclaims all other warranties including, without limitation, all implied warranties of merchantability and fitness for a particular purpose.

EXCLUSIVE REMEDY

Notwithstanding the foregoing, the purchaser's exclusive remedy for any breach of warranty, express or implied, is limited to the repair or replacement of the defective unit or the refund of the purchase price, at the option of Cary Audio Design, Inc. Under no circumstances is Cary Audio Design, Inc. liable for incidental or consequential damages. Any implied warranties imposed by law terminate one (1) year from the date of purchase.

FOREIGN PURCHASERS

Cary Audio Design, Inc. warrants its merchandise to purchasers in the United States for use in the United States. It provides no other warranties. If you are a foreign purchaser, consult with your dealer to determine whether your dealer provides any warranty.

The foregoing constitutes Cary Audio Design Inc.'s entire obligation with respect to this product, and the original purchaser and any user or owner shall have no other claim for incidental or consequential damages. Some states do not allow the exclusion or limitation of incidental or consequential damages, so the above limitation and exclusion may not apply to you.

This warranty gives legal rights and you may have other rights which vary from state to state.