

CARY AUDIO DESIGN, INC.

OPERATING MANUAL

CAD2A3

CLASS A STEREO AMP

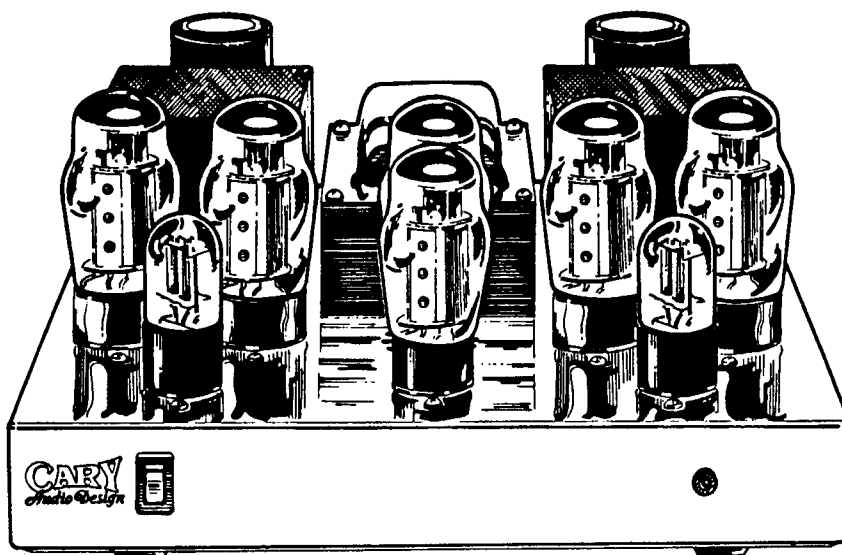

NOTE:

Before installing your new CAD-2A3, please read this manual carefully as it will inform you of the CAD-2A3's specifications, proper installation procedures and operation procedures. Also included in this manual are guidelines on how to properly service and care for your new CAD-2A3.

CAD-2A3
Triode Stereo Amplifier

INTRODUCTION

Congratulations! You have purchased one of the most exotic audio amplifiers available. The 2A3 triode tube in the CAD-2A3 amplifier is a REAL triode audio tube. These output tubes offer far greater linearity and lower distortion than tetrode or pentode audio output tubes. The CAD-2A3 is operated in the Class "A" mode.

The CAD-2A3 is constructed to the highest commercial standards utilizing a grain oriented stainless steel, nickel chrome plated chassis. All resistors are 1% metal film and the audio coupling capacitors are made of polypropylene. Each CAD-2A3 is hand wired point to point. The high voltage DC power supply contains two computer grade electrolytic capacitors for a total of 2200 MFD. The CAD-2A3 utilizes a pair of 5V4G full wave rectifier tubes in the power supply. A 6SL7 tube is used as the predriver, and, of course, the famous 2A3 triode output tubes in a push-pull output configuration. The output transformer is a triode design specifically designed by Cary Audio for use in the CAD-2A3. This output transformer is the most important component in the entire amplifier. All CAD-2A3 stereo amplifiers are burned in at the factory for a 48 hour period. This burn-in period will assure you of a trouble free amplifier, right out of the box.

The most exciting feature of the CAD-2A3, aside from how gorgeous it looks, is the delightful, sensual beauty of the music it recreates. The first thing that will strike you about your new CAD-2A3 is the incredible transparency and resolution of detail in the music. The CAD-2A3's sensual nature is best revealed in the sense of life it displays in female vocalists.

This amp presents music with such presence and directness, you'll be drawn into the music hour after musically satisfying hour. This is the result of circuit techniques, which eliminate any discernable crossover notch at low levels, and also contributes to the freedom from listening fatigue. The CAD-2A3 will draw you in even further as you realize how lucid and utterly uncolored neutrality reveals delicate nuances in the sound stage.

SPECIFICATIONS

Operating the CAD-2A3 stereo amplifier is a simple procedure since each unit is designed for long term stability in virtually any home operating situation. Therefore, if the unit is operated outside the parameters outlined in this owner's manual, damage may result. Please read this manual carefully before putting your new Cary Audio Design CAD-2A3 in operation.

The following definitions are applicable to this manual. These definitions must be followed explicitly.

WARNING
HAZARD PRESENTS PERSONAL INJURY OR DEATH

Caution
EQUIPMENT DAMAGE MAY OCCUR BUT NOT PERSONAL INJURY

Note
Proper performance of the amplifier cannot be ensured if disregarded

1.2 Specifications

The following section describes the CAD-2A3's basic specs. Specifications are subject to change without notice or obligation.

DIMENSIONS: 6"H x 13"W x 12"D

WEIGHT: 38 Lbs.

CIRCUIT TYPE: Push-Pull in Class A.

POWER OUTPUT: 1KHz sign wave
7.5 volts RMS across 4 ohms=14 watts
11 volts RMS across 8 ohms=15 watts

INPUT SENSITIVITY: 1.5 volts for full output

INPUT IMPEDANCE: 100,000 ohms

NOISE AND HUM: 80dB below rated output

FREQUENCY RESPONSE (at one watt output): 10Hz to 30,000Hz + 0 - 0.75dB
(at full power output): 15Hz to 23,000Hz + .5 - 0.50dB

DAMPING FACTOR: Greater than 30

TUBES: 2-6SL7 predrivers, 4-2A3 Triode output, 2-5V4G Rectifier

TRANSFORMERS: 1-EI laminated core power transformer
2-Special triode output transformers
100% duty cycle on all transformers

RESISTORS: 1% metal film

CAPACITORS: Polystyrene and polypropylene

POWER SUPPLY CAPACITORS: 2-1100 MFD @ 450VDC, 223 Joules

AC CORD: 3 conductor shielded

AC POWER REQUIREMENTS: 117 volts AC 50/60 Hz
225 watts operate
90 watts in stand by (option)
220 volts AC 50/60 Hz
225 watts operate
90 watts in stand by (option)

WARM-UP TIME: 3 minutes

BREAK-IN PERIOD: 100 hours of music playing time

FINISH: Nickel chrome plated stainless steel

1.3 Front Panel Features

AC-ON ROCKER SWITCH: Turns AC power on in the "up" position.

LED: Indicates high voltage DC on (with optional stand-by switch the Red LED will not light with unit in stand-by).

1.4 Rear Apron Features

INPUT: Signal input connection via shielded interconnect cable

OUTPUT: The 5-way binding posts provide the output to the speaker system. Red=+, Black=-

CAUTION
EQUIPMENT DAMAGE MAY OCCUR WITH IMPROPER FUSES

AC: 3 conductor shielded power cord to AC power mains

CAUTION
USE OF ANY OTHER PROTECTION FUSE CAN DAMAGE UNIT

FUSE: AC power fuse. Never replace with any other valve than 2 AMP SLOW BLOW! 250 VOLT!

STAND-BY (optional): In the "up" position, the CAD-2A3 is in the operate mode. In the "down" position, the high voltage B+ power supply is turned off and the front panel Red LED will not light.

GND: For "audio-purists" this should be connected to an earth ground rod via the shortest lead possible - this is not essential for proper operation. The earth ground will help insure immunity to RF interference and AC ground loops.

CAUTION

NEVER REMOVE/INSERT AC LINE CORD WHEN THE UNIT IS ON

TUBE FUSE: This is an overcurrent protection fuse for the output tubes. Never replace with any other valve than 1/2 AMP FAST BLOW! 250 VOLT!

TO INSTALL THE 2A3 TUBES, REFER TO PAGE 11 OF THIS MANUAL AND READ INSTRUCTIONS CAREFULLY!

INSTALLATION

This section describes the unpacking and installation procedures for the CAD-2A3 amplifier.

WARNING
MAKE NO ATTEMPT TO PUT THE CAD-2A3 AMPLIFIER IN SERVICE
WITHOUT THE BOTTOM PLATE ATTACHED - CONTACT WITH VOLTAGE
IN THE CAD-2A3 CAN BE FATAL!!!

2.2 Unpacking

All shipping containers have been specifically designed to protect their contents and special care has been taken to prevent damage under normal shipping conditions. Mishandling should be evident upon inspection of the shipping container. If damage is found after visual inspection, take care not to destroy the evidence. If necessary, document the damage with photographs and contact the transport carrier immediately.

Carefully remove your new CAD-2A3 amplifier from its packing carton, and examine it closely for signs of shipping damage. It is recommended to save all original packing cartons to protect your amplifier from damage should you wish to store it or ship it for after-sales service.

2.3 Warranty Card

Fill out the enclosed warranty registration card and return to Cary Audio Design, Inc. within 10 days of original purchase. Keep your original sales slip with the packing cartons should you ever need it for reference. **Failure to register warranty will limit the warranty to one year.**

2.4 Amplifier Placement

In general, the location of your new CAD-2A3 amplifier is not critical. The best placement in your system is near the speaker system with short lengths of speaker cables. Certain precautions must be taken to ensure optimum performance. Avoid extremely hot locations such as near radiators or other heating units. Keep the top of the CAD-2A3 clear of books, paper or other equipment to protect against overheating.

2.5 Power Requirements

The CAD-2A3 is designed to operate from house current mains. The design voltage is 117VAC at 50/60Hz. (Foreign units 220 VAC at 50/60Hz)

2.6 Cables

The speaker cables from the output posts of the CAD-2A3 to the speaker system can be any convenient length your set-up requires. Select speaker cables of sufficient size to preserve the outstanding performance capabilities of your CAD-2A3. Heavy gauge #16 wire is suitable for distances up to 10 feet; #12 for 25 feet. Most audio dealers will have proper speaker cable in stock for this purpose.

OPERATION

Signal input connections are made via the input jack on the rear of the CAD-2A3 located next to the output binding posts. The interconnect cables from the output of the preamplifier can be any convenient length your set-up requires. The choice of a high quality interconnect cable is important. Once again, your audio dealer will have the proper cables in stock for this purpose.

3.1 Operation

Your new CAD-2A3 is ready for operation after the speaker, interconnect cables and all the tubes have been installed. See page 11 for tube positions.

3.2 AC On Power Switch

Simply push the AC rocker switch up to the ON position. The RED LED on the front panel will light after about 30 seconds as the B+ high voltage comes up. Observe that all tubes are lit (filaments).

3.3 Stand-By Switch (Optional)

This is a most convenient feature on the CAD-2A3 amplifier. This switch is located on the rear of the amplifier. In the "up" position, the amplifier is ready to operate. In the "down" position (provided the front panel AC switch is in the "on" position), only the tube filaments are operating. You may wish to leave your CAD-2A3 amp turned on in the stand-by mode 24 hours a day. When you wish to listen to music, simply flip the stand-by switch in the "up" position. Under these conditions the CAD-2A3 is always warmed up and ready for peak performance.

3.4 Break In Period

The tubes, capacitors and output transformers take approximately 100 hours of music playing to fully settle in for peak performance. The CAD-2A3 may seem sterile or thin sounding right out of the box. After the first couple of hours you will notice increased depth and tighter bass. This break in period defies all engineering theory, but is true with most audio amplifiers.

<p style="text-align: center;">WARNING MAKE SURE AMPLIFIER IS UNPLUGGED FROM AC MAINS FOR ANY SERVICE OR CLEANING!</p>

SERVICE AND CARE

4.1 CAD-2A3 Care and Cleaning

The chassis of the CAD-2A3 may be cleaned with a soft rag and Windex (or a similar window cleaner). The frequency of cleaning will be governed by how many hours the CAD-2A3 is operated and by operating environmental cleanliness.

4.2 Tube Replacement

If it becomes necessary to replace the tubes in the CAD-2A3 amplifier, a matched set of tubes of the same brand should be used. A new tube kit is available from Cary Audio Design, Inc. You should get year's from the output tubes with everyday usage and many, many years of use from the 6SL7 input tubes and 5V4G rectifier tubes.

4.3 Factory Service

Careful consideration has been given to the design of your CAD-2A3 amplifier to keep maintenance problems to a minimum. However, it is possible that some problems may arise which cannot be cured by tube substitution. At this point we suggest that you contact our Customer Service Department, phone number 1-919-481-4494, to describe your problem in detail. Do not return the CAD-2A3 to the factory without a return authorization number from the Customer Service Department. Cary Audio Design, Inc. will assume no responsibility if the transportation company refuses to pay a damage claim due to your improper packing or lack of insurance should the unit be lost in shipment.

WARNINGS

MAKE NO ATTEMPT TO PUT THE CAD-2A3 IN SERVICE OUTSIDE OF THE CABINET. CONTACT WITH HIGH VOLTAGES FOUND IN THE UNIT CAN BE FATAL!!!

COMPLETELY REMOVE AC POWER PLUG FROM THE WALL AND ALLOW 30 MINUTES FOR THE HIGH VOLTAGE CAPACITORS TO DISCHARGE THROUGH BLEEDER RESISTORS BEFORE ATTEMPTING TO CHANGE TUBES OR CLEAN THE INSIDE OF THE AMPLIFIER.

CAUTIONS

NEVER REMOVE/INSERT AC PLUG WHEN THE UNIT IS ON OR THE AC POWER SWITCH IS IN THE "ON" POSITION.

OBSTRUCTION OF THE TOP PORTION OF THE CAD-2A3 WILL RESULT IN TUBES OVERHEATING.

*****OBSERVE DIRECTIONS IN THIS MANUAL*****

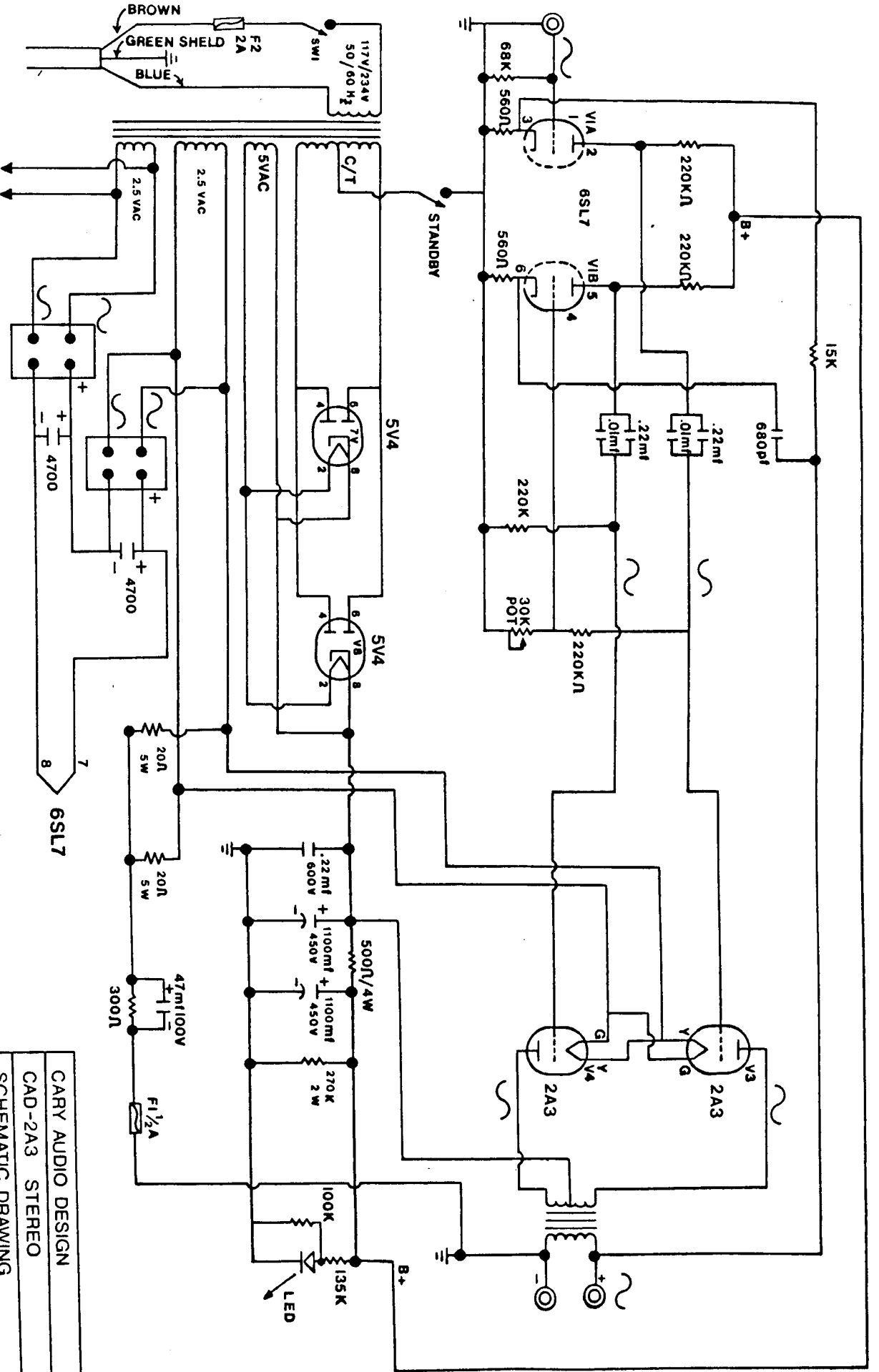

TO 2A3's
SECOND CHANNEL

One Channel & Power Supply

CARY AUDIO DESIGN
CAD-2A3 STEREO
SCHEMATIC DRAWING

REAR

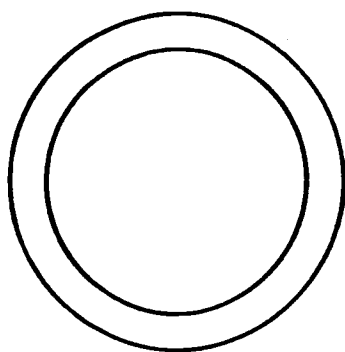

MODEL: _____

SERIAL NO: _____

SERIAL NO: _____

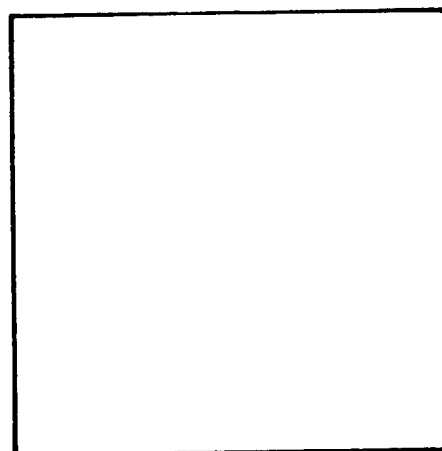
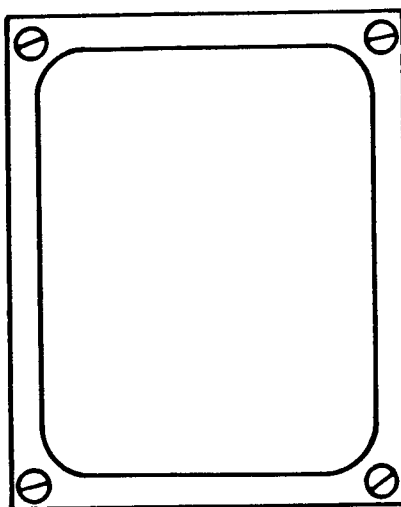
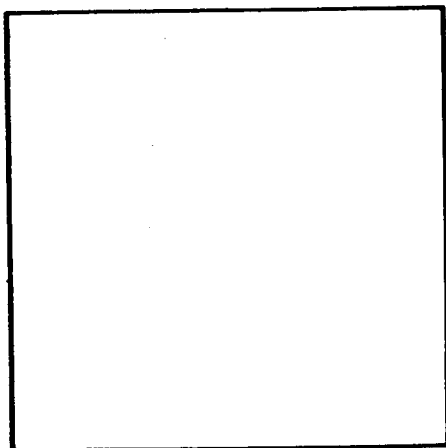
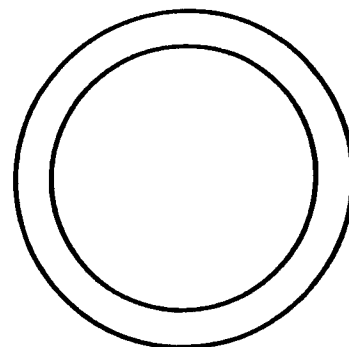

2A3-Large Pins Position In Front

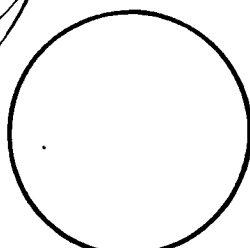
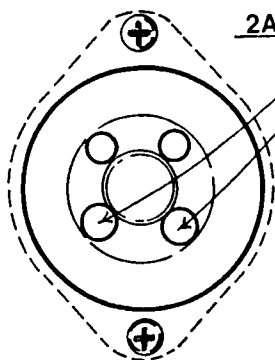

2A3

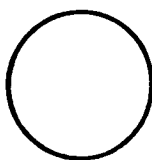

5V4

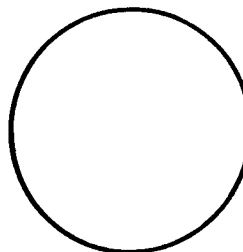

2A3

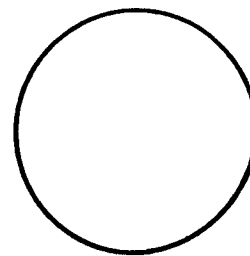

2A3

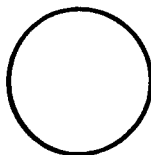

6SL7
WGT

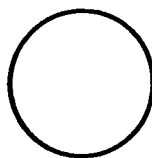

5V4

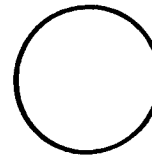

6SL7
WGT

FRONT

IMPORTANT! IMPORTANT!

THE TWO LARGE PINS ON THE BASE
OF THE 2A3 TUBES MUST FACE
THE FRONT OF THE CAD-2A3 AMPLIFIER!!

CARY
Audio Design
INC.

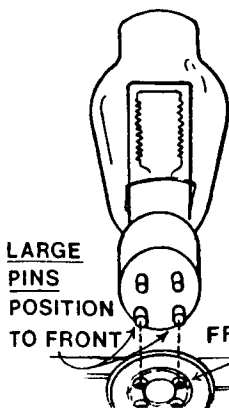

TUBE
2A3

LARGE
PINS
POSITION
TO FRONT

FRONT - PINS BASE LARGE

FEEDBACK CONTROL SWITCH
RIGHT CHANNEL

FEEDBACK CONTROL SWITCH
LEFT CHANNEL

ZERO FEED BACK

8 db - FEED BACK

6SL7 Filament Voltage

FILAMENT POWER SUPPLY

FRONT

CARY
Audio Design

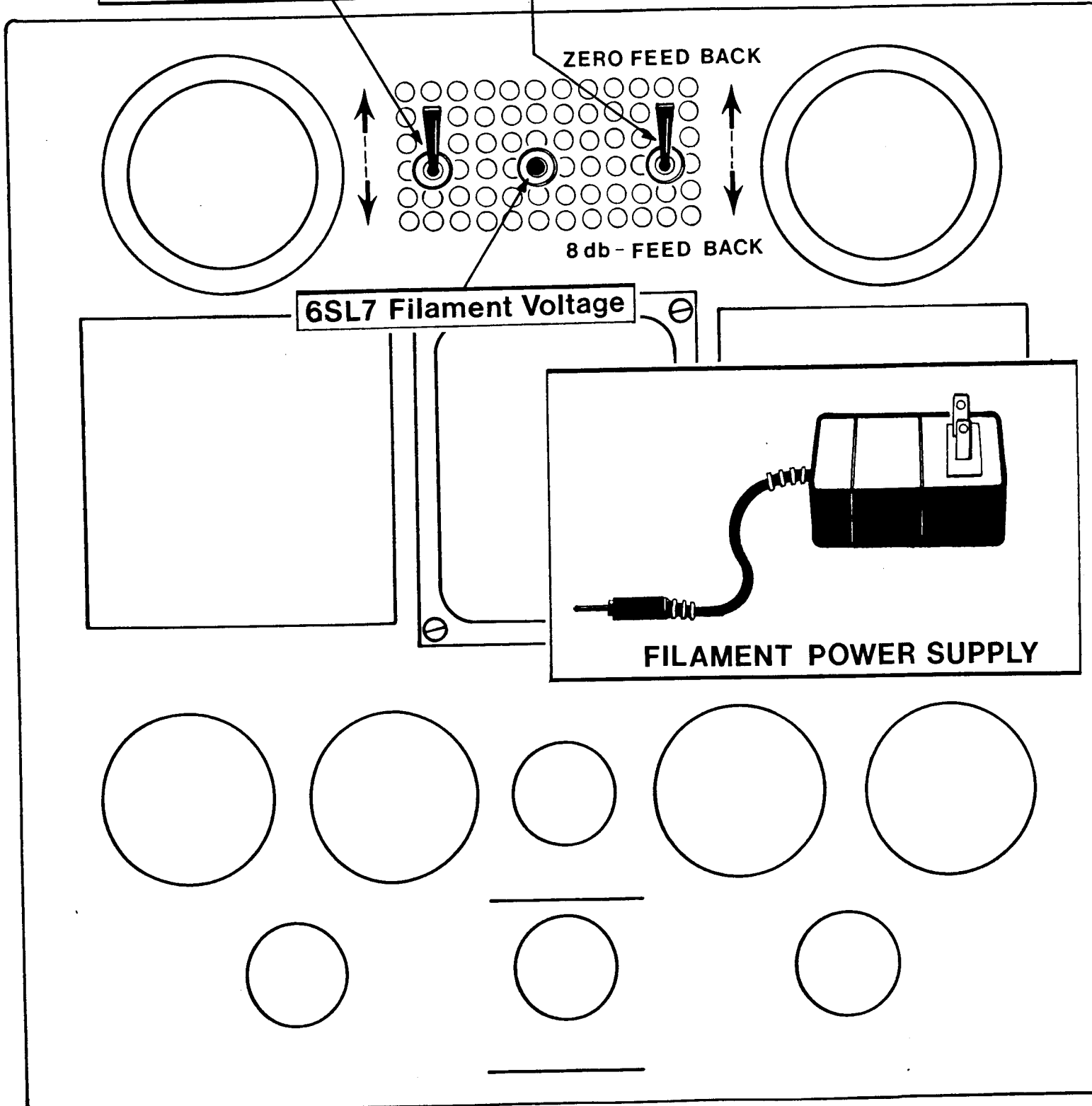

UNITED STATES LIMITED WARRANTY

Cary Audio Design, Inc. warrants to the original United States purchaser for use in the United States, that this product shall be free from defects in material (except tubes and AF output transistors) or workmanship for three (3) years from the date of the original purchase.

During the warranty period, Cary Audio Design, Inc. or an authorized Cary Audio Design, Inc. service facility will provide free of charge both parts (except tubes and AF output transistors) and labor necessary to correct defects in material or workmanship.

To obtain such warranty service, the original purchaser must:

- (1) Complete and send in the warranty Registration Card.
- (2) Notify Cary Audio Design, Inc. as soon as possible after the discovery of a possible defect, of:
 - (a) The model number and serial number;
 - (b) The identity of the seller and the approximate date of purchase;
 - (c) A detailed description of the problem, including details on the electrical connection in the associated equipment and the list of such equipment.
- (3) Deliver the product to Cary Audio Design, Inc. or the nearest authorized service facility, or ship the same in its original container or equivalent, fully insured and the shipping charges prepaid.

Correct maintenance, repair and use are important to obtain performance from this product. Therefore, carefully read the Instruction Manual. This warranty does not apply to any defect that Cary Audio Design, Inc. in its sole discretion determines is due:

- (1) Improper maintenance or repair, including the installation of parts or accessories that does not conform to the quality and the specifications of the original parts.
- (2) Misuse, abuse, neglect or improper installation.
- (3) Accidental or incidental damage.

Warranty Disclaimer

Except for the express warranties stated herein, Cary Audio Design, Inc. disclaims all other warranties including, without limitation, all implied warranties of merchantability and fitness for a particular purpose.

Exclusive Remedy

Notwithstanding the foregoing, the purchaser's exclusive remedy for any breach of warranty, express or implied, is limited to the repair or replacement of the defective unit or the refund of the purchase price, at the option of Cary Audio Design, Inc. Under no circumstances is Cary Audio Design liable for incidental or consequential damages. Any implied warranties imposed by law terminate one (1) year from the date of the original purchase.

Foreign Purchasers

Cary Audio Design, Inc. warrants its merchandise to purchasers in the United States for use in the United States. It provides no other warranties. If you are a foreign purchaser, consult with your dealer to determine whether your dealer provides any warranty.

The foregoing constitutes Cary Audio Design, Inc.'s entire obligation with respect to this product, and the original purchaser and any user or owner shall have no other claim for incidental or consequential damages. Some states do not allow the exclusion or limitation of incidental or consequential damages, so the above limitation and exclusion may not apply to you.

This warranty gives legal rights and you may also have other rights which vary from state to state.